

IOLINE SUMMIT 910 MARKER PLOTTER
GUIDE TO OPERATIONS

Ioline Corporation
Kirkland, Washington

This is the first edition of the
Summit 910 Marker Plotter Guide to Operations.
Subsequent updates or revisions will be announced on this page.

Copyright © 1995, Ioline Corporation
All rights reserved
Printed in the United States of America
PN 105400 Rev 1
March 1997

Table of Contents

1 INTRODUCTION.....6
YOUR APPAREL DESIGN MARKER PLOTTER 6
HOW THE SUMMIT 910 MARKER PLOTTER WORKS ... 7
SAFETY AND PRECAUTIONS 8

2 ASSEMBLY 9
ASSEMBLING THE STAND 9
ATTACHING THE SUMMIT 910
MARKER PLOTTER TO THE STAND 13
LEVELING THE STAND..... 17
CONNECTING THE SERIAL CABLE
AND THE POWER CORD 20
POWER ON 21
LOADING A PEN 21
LOADING PAPER 21

3 OPERATING THE SUMMIT 910 31
FRONT PANEL CONTROLS..... 31
Start/Stop 32
Arrow Keys 32
Start Point 33
Pen Force 33
Roll Keys 33
Sensor Test..... 34

**4 SENDING AND CANCELING
MARKER PLOT FILES..... 35**
SENDING A MARKER PLOT FILE 35
From Your Apparel Design Software 35
From the Ioline Control Center 35
CANCELING A MARKER PLOT..... 36
From Your Apparel Design Software 36
From the Ioline Control Center 37

5 THE IOLINE CONTROL CENTER.....38
INSTALLING THE IOLINE CONTROL CENTER..... 38
 Windows Installation 39
 DOS Installation.....41
 Macintosh Installation..... 42
CHANGING YOUR SYSTEM SETTINGS..... 43
 English or Metric Measurement Units.....43
 Acceleration.....43
 Speed.....44
 Up/Down Delays.....44
 Adjusting the Frame Gap44
 HPGL 7475 or 7596 Plotter Language/DMPL 45
 Force45
 Panel Size.....46
 Scale.....46
 Set Factory Settings46
 Send Settings to Summit 910: Temporary46
 Send Settings to Summit 910: Permanent.....47
 Calibrate.....47

6 PREVENTIVE MAINTENANCE.....48
CLEANING THE GRIT SHAFT.....48
CLEANING THE PLATEN 50
CLEANING THE SUPPORT BLOCKS 52
REMOVING THE DUST COVER 53
CLEANING THE TRAVERSE EXTRUSION AND
CARRIAGE V-WHEELS..... 56

7 TESTING AND TROUBLESHOOTING58

DIAGNOSTIC TESTING..... 58

 Testing The Summit Marker Plotter/Computer
 Communications 58

 Testing The Summit Marker Plotter Port 59

 Testing Your Computer Port..... 60

TROUBLESHOOTING 61

 No Power When You Turn on the Summit 910..... 66

 The Summit 910 Won't Respond to Your Computer..... 66

 Loss of Registration Within a Frame 67

 Loss of Registration Between Frames 68

 Poor Line Quality..... 69

1 INTRODUCTION

YOUR APPAREL DESIGN MARKER PLOTTER

Congratulations on purchasing a Summit 910 Marker Plotter. This guide will show you how to install and use this fast, accurate, and reliable machine. To plot markers, you also need a computer and apparel design software. The computer must have the apparel design software installed in order to create marker plot files. The apparel design software helps you design patterns and then turn your completed patterns into marker plot files that the Summit 910 Marker Plotter can use to produce markers.

The Summit 910 also comes with its own software (the Ioline Control Center) that you can install on your computer. The Ioline Control Center software allows you to adjust a variety of Summit marker plotter settings from your computer.

The Summit 910 is a wide format plotter. The automatic paper advance creates and maintains the feed and the takeup loops while the Summit 910 is working and it winds up the completed marker on the takeup shaft. The maximum capacity of the takeup shaft is 10 yards (9.1 meters).

HOW THE SUMMIT 910 MARKER PLOTTER WORKS

When the Summit 910 plots a marker, it moves the paper back and forth (along the X-axis) and moves the pen from side to side (along the Y-axis).

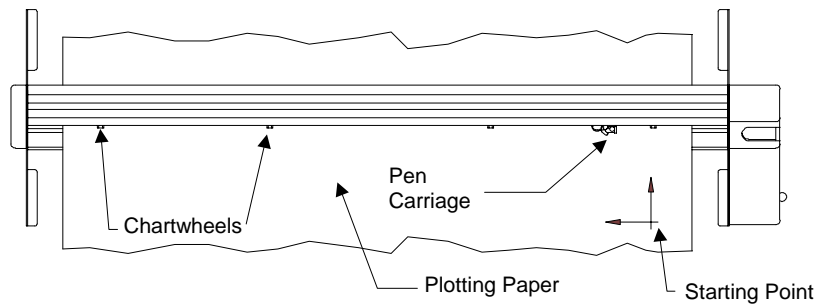

Figure 1. The X and Y Axes (top view)

You will learn to make a variety of adjustments that will allow you to produce completed markers with as much speed and precision as possible.

Note: When we refer to the right or left side of the Summit 910, we mean the right or left side as you face the front of the unit.

SAFETY PRECAUTIONS

The Summit 910 Marker Plotter's pen can move very quickly. Always observe the following safety precautions:

- Be careful of your hair, jewelry, or loose clothing near the Summit 910. They can become caught in the mechanical parts.
- Never move the pen carriage or grit shaft by hand. Use the keypad arrow keys and let the machine do it.
- Use caution when you are changing a pen.
- Keep your hands away from the pen carriage when the Summit 910 is working.
- Never run the Summit 910 with either the dust cover or the end covers removed.
- Do not try to repair the machine yourself, without factory authorization. If you need to make mechanical adjustments, turn off the Summit 910 and disconnect it from all power sources (including the computer and the wall outlet).

2 ASSEMBLY

ASSEMBLING THE STAND

Check your packing list to make sure you have all of the accessories. Carefully remove the plotter from the box and place it on a flat surface until you are ready to attach it to the stand. Save all packing materials and your box. Assembling the stand requires two people. One person should hold the pieces in place while the other person uses the supplied hex wrench and screws to fasten them together. When we refer to the right or left side of the Summit 910 Marker Plotter in these procedures, we mean the right or left side as you face the front of the unit. You must assemble the stand on a flat, level surface.

Assemble the stand in the following manner:

1. Use two of the long screws and four of the short screws (and the supplied hex wrench) to attach a stand foot to one of the stand legs. Note the orientation of the threaded nuts on the stand foot and the position of each of the screws in Figure 2. Slip the stand leg over the foot and then insert the four short screws through the outer leg flanges and into the threaded nuts in the foot. Insert the two long screws directly into the middle holes in the stand foot.

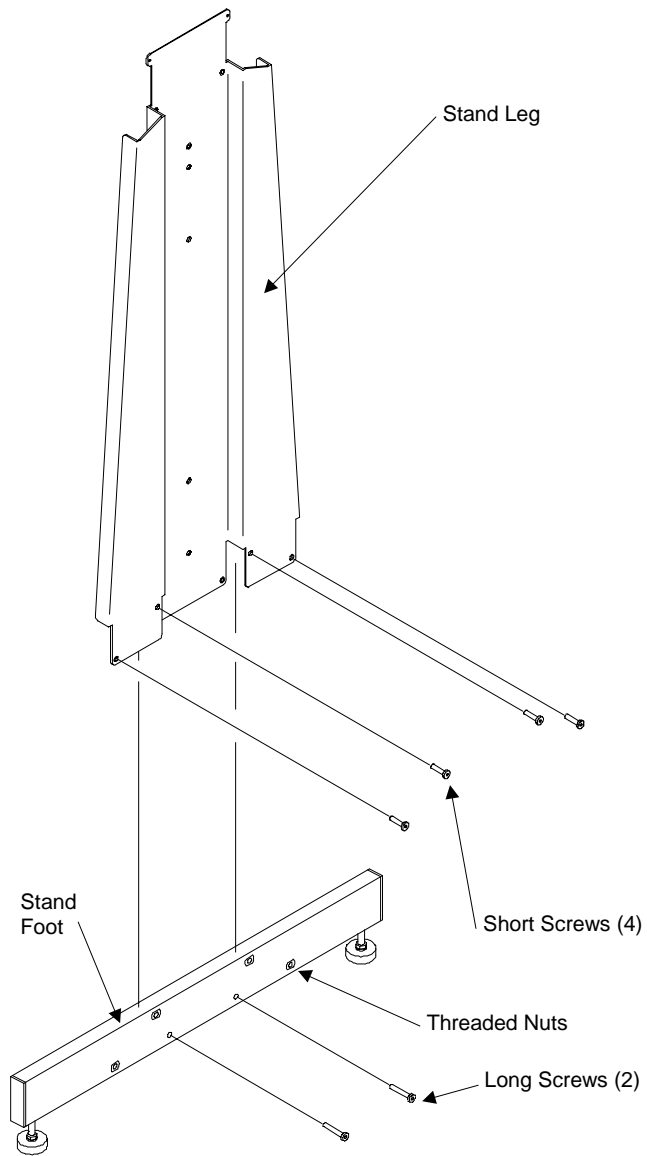

Figure 2. Attaching a Stand Foot to a Stand Leg

2. Repeat procedure #1 to attach the remaining stand foot to the remaining stand leg.
3. Use two of the long screws and the hex wrench to attach the bottom crossmember to one of the stand legs. Refer to Figure 3.

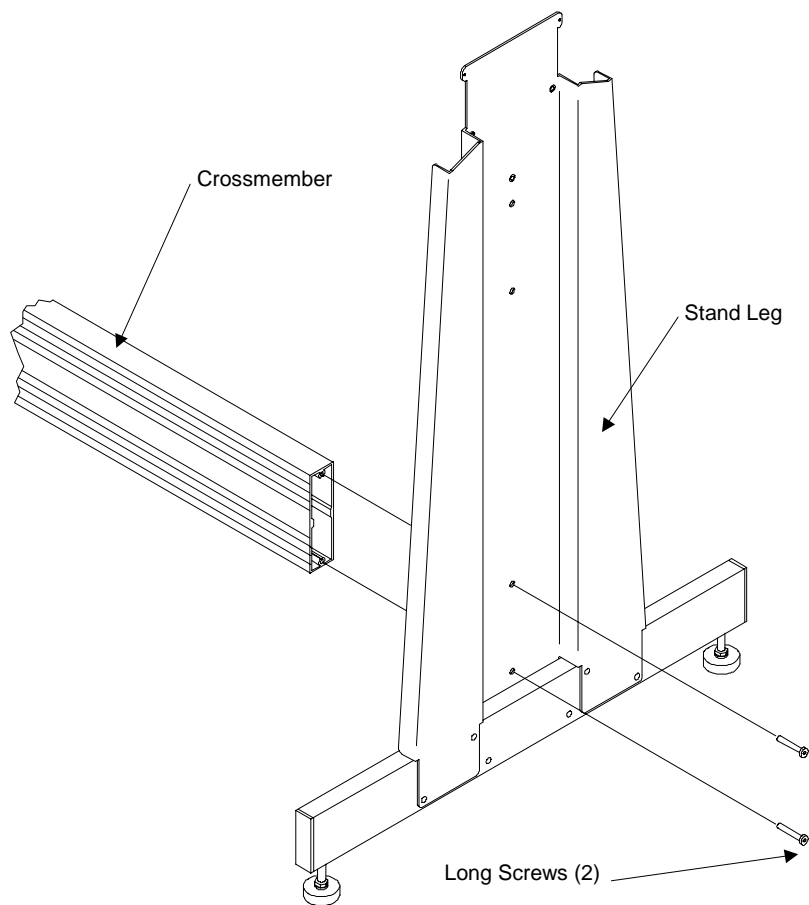

Figure 3. Attaching the Bottom Crossmember to a Stand Leg

- Repeat procedure #3 to attach the other end of the crossmember to the other stand leg. Refer to Figure 4.

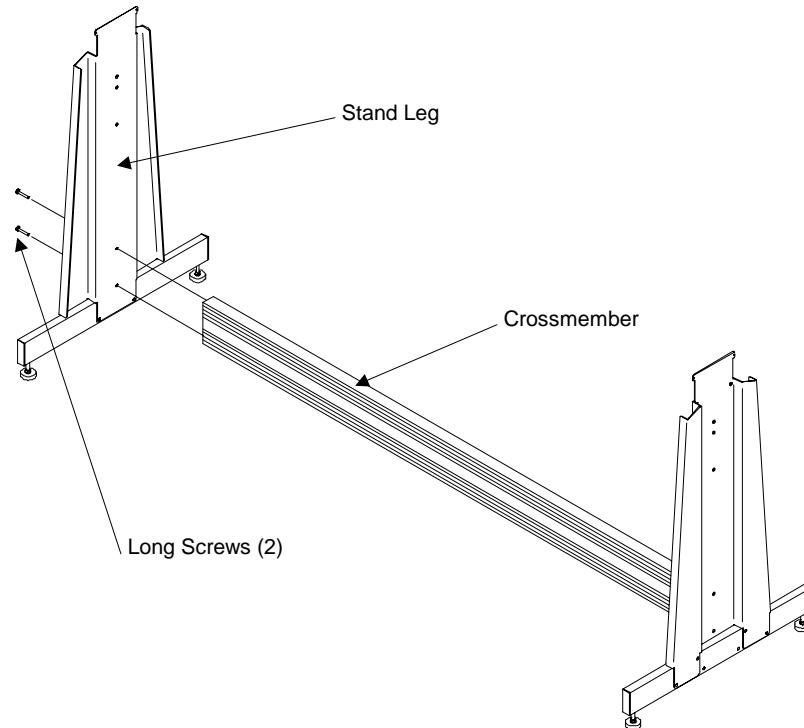

Figure 4. Attaching the Bottom Crossmember to the other Stand Leg

- Use two of the long screws and the hex wrench to attach each end of the top crossmember to the stand legs. Refer to Figure 5.

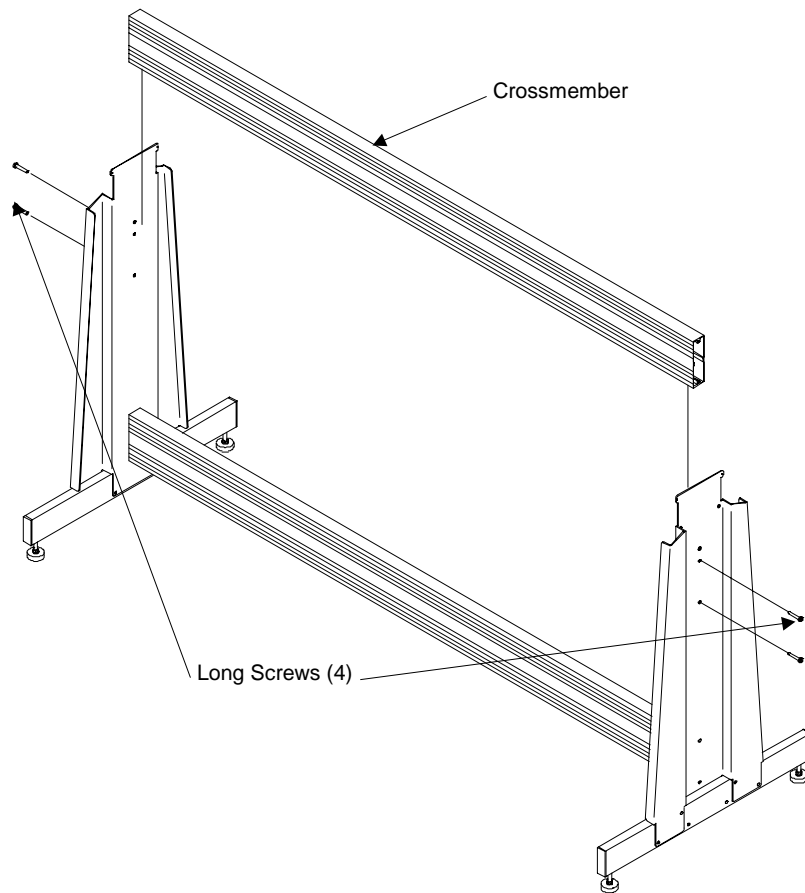

Figure 5. Attaching the Top Crossmember to the Stand Legs

**ATTACHING THE SUMMIT 910 MARKER PLOTTER
TO THE STAND**

Attaching the Summit 910 to the stand requires two people.
Attach the Summit 910 to the stand in the following manner:

1. Unscrew and remove the round black transmission knob from the roll feed transmission drive shaft on the right side of the Summit 910. Note the position of the transmission knob in Figure 6.

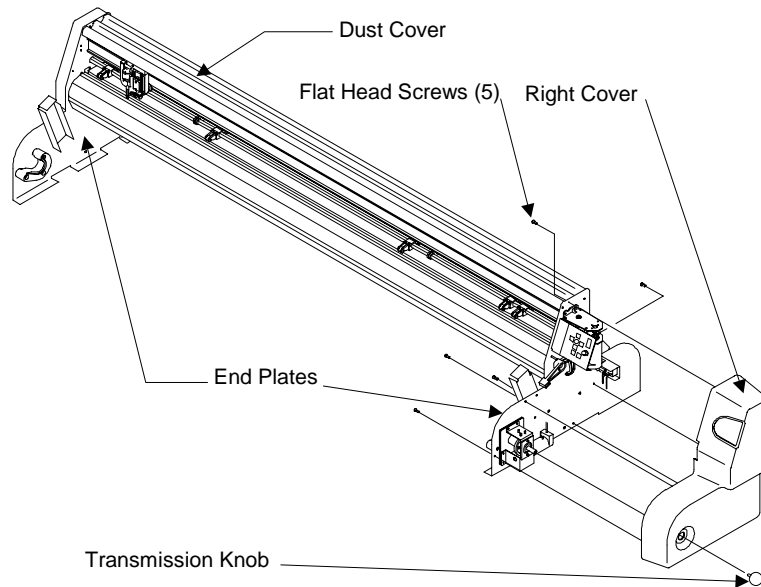

Figure 6. Removing the Transmission Knob and the Right Cover

2. Remove the five black, flat head screws (from the inside of the right end plate) that hold the right cover to the right side of the Summit 910. Remove the cover.
3. One person should be positioned at each end of the plotter. Grasp the end plates and gently lift the Summit 910 onto the stand.

Warning: Lift the plotter only by the end plates. Do not lift it by the dust cover, the motors, the keypad, or the pen carriage. Doing so may permanently damage your Summit 910 Marker Plotter.

4. Use six of the short screws and the hex wrench to attach the Summit 910 to the stand. Use three screws to attach each end plate to a stand leg. Use the top two left end screws to attach the tool tray to the stand. The tool tray is in the accessory kit.

Note: Tighten the screws carefully. Make sure you don't over-tighten them.

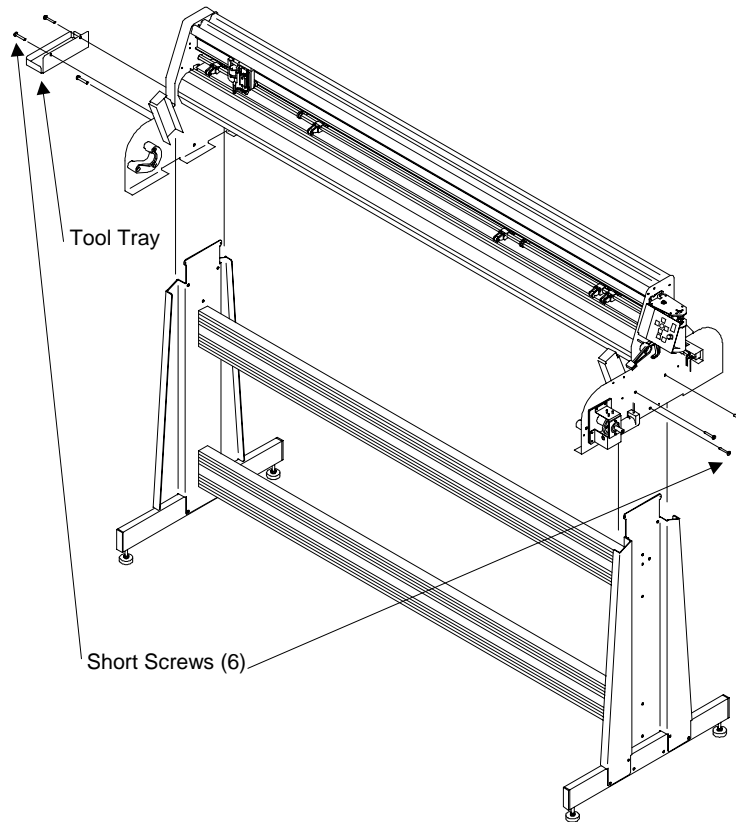

Figure 7. Attaching the Plotter and the Tool Tray to the Stand

5. Attach the two static dissipaters to the stand. Place the hooks in each end of the static dissipaters through the holes in the stand legs. Refer to Figure 8.

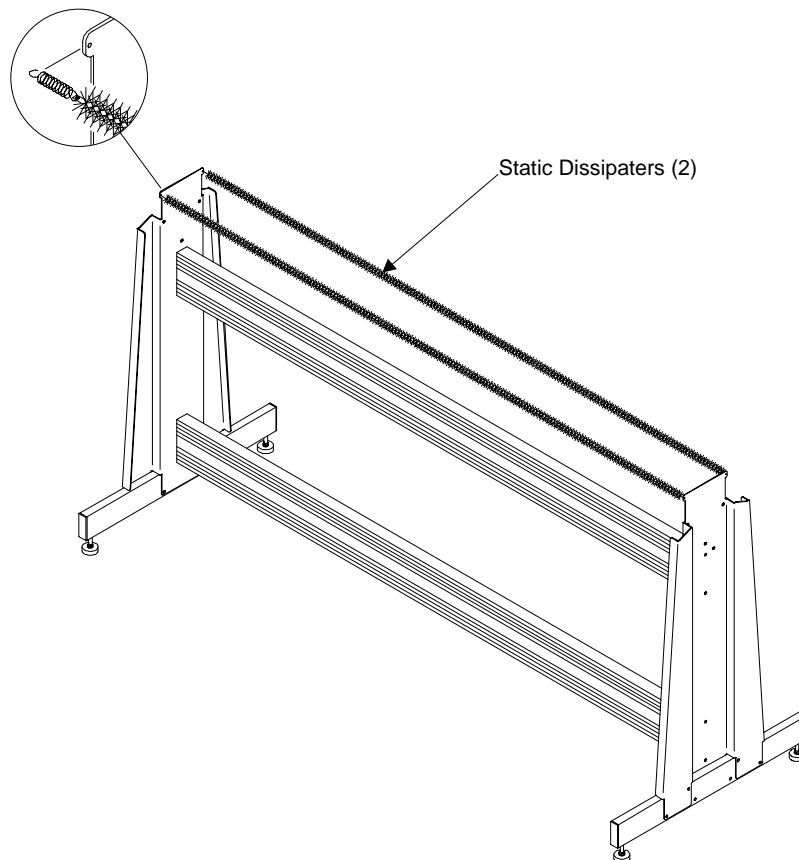

Figure 8. Attaching the Static Dissipaters

6. Reinstall the five black, flat head screws to reattach the right end cover to the right side of the Summit 910. Install the top screw first. Use the access hole in the stand leg to install the lower screw. Refer to Figure 6.
7. Reattach the transmission knob.

LEVELING THE STAND

Note: Make sure the stand is on a flat, level surface. When the Summit 910 Marker Plotter is attached to the stand, the entire unit must be level. The feed shaft and the takeup shaft and the plotter itself must all be aligned and parallel to ensure proper operation. Adjust the leg levelers in the following manner (Refer to Figure 9):

1. Place a level on the flat surface in the center of either stand leg.
2. Use an adjustable wrench to loosen the lock nut of one of the leg levelers.
3. Turn the leg leveler to raise or lower one leg assembly until it is level.

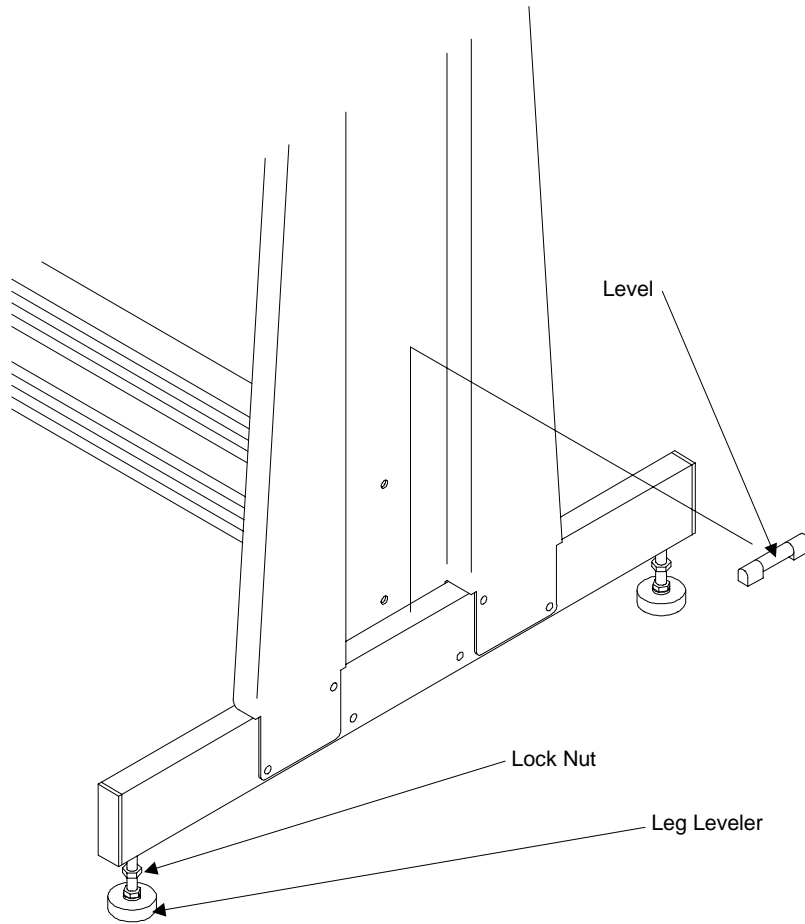

Figure 9. Leveling the Legs

4. Repeat the leg leveling procedure for the other leg.
5. Now level the stand by placing the level on the flat surface in the center of the bottom crossmember. (Figure 10)

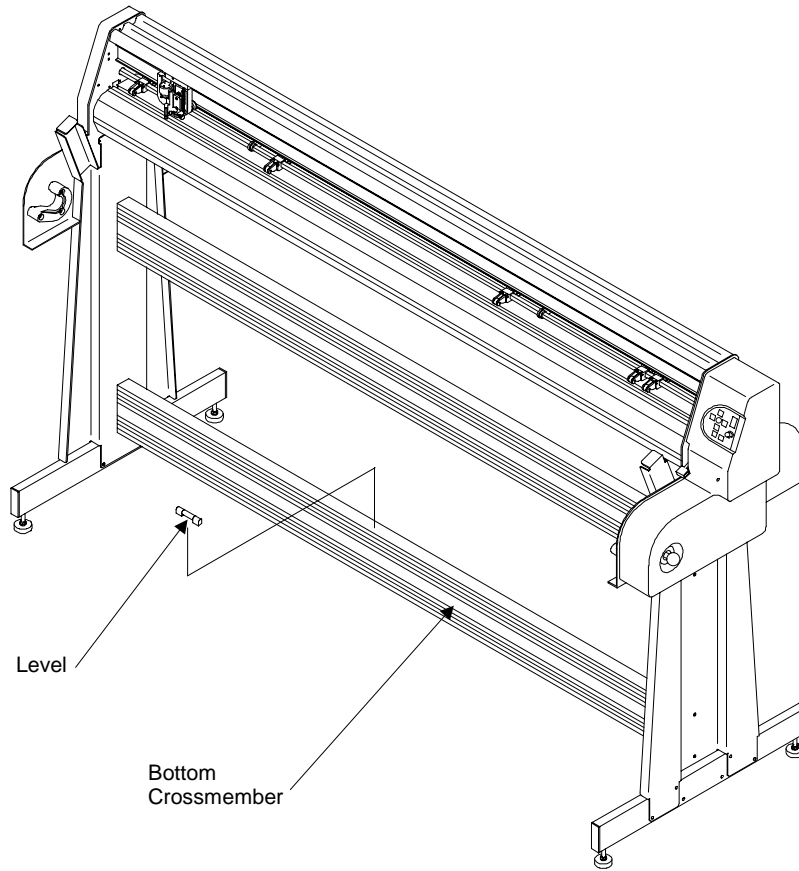

Figure 10. Leveling the Stand

6. Use a wrench to raise or lower both ends of one of the legs until the stand is level, lengthwise. Make sure you turn the wrench the same amount for both the front and rear leg levelers of the leg.
7. When the stand is level, tighten all four leg leveler lock nuts.

CONNECTING THE SERIAL CABLE AND THE POWER CORD

! Make sure your computer and the Summit 910 are off!

Use the power cord in your accessory kit to connect the Summit 910 to a surge protector. Use your computer's power cord to connect your computer to the same surge protector. Plug the surge protector into a grounded 3-prong wall outlet. Connect the serial cable to the serial port on the rear panel of the Summit 910. Use the cable to connect the serial port on the back of the Summit 910 to the serial port on the back of your computer.

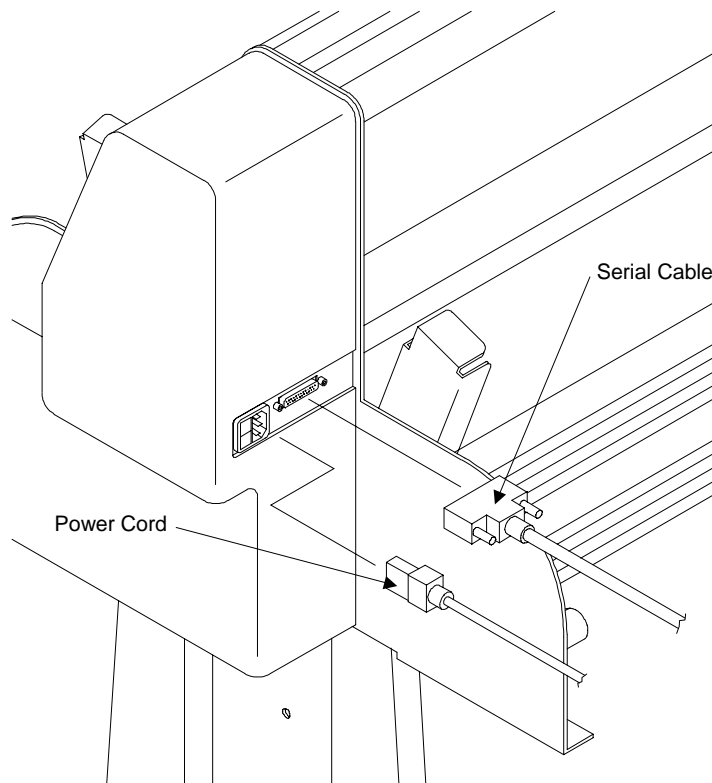

Figure 11. The Summit 910 Marker Plotter's Rear Panel

POWER ON

The power switch is in back of the Summit 910. Turn on the Summit 910 Marker Plotter and the computer to make sure both work. The Summit 910 Marker Plotter's pen carriage will move when the power comes on. Keep your hands and loose clothing away from all moving parts of the Summit 910. The Summit 910 will be in Stop mode (red light on) when you turn on the plotter.

LOADING A PEN

You can use any pen that has a diameter of .25" to .90" (6.4 mm to 22.9 mm), or any Hewlett Packard compatible pen. When you select a pen to use with the Summit 910, keep in mind that a pressurized ball point pen is optimal. A pen with a ball writer tip is the second best, and a pen with a plastic tip is the third best choice. We do not recommend using a pen with a ceramic tip.

Gently insert the flange of the pen between the grooves of the pen holder and tighten the thumb screw.

LOADING PAPER

Important: To allow the paper roll to adjust for temperature and humidity, it should be placed in the area to be used at least one day before loading.

1. Place a paper hub in each end of the new paper roll. Use a rubber mallet to drive the hubs in as far as they will go.
2. Slide the feed shaft through the paper hubs and the paper roll. If a paper hub falls off the paper roll, press it firmly back into the end of the paper roll.

Note: You must firmly insert the paper hubs and make sure they stay in place.

3. Lift the feed shaft (with the paper roll) into the rear feed shaft support blocks. Make sure the paper hangs over the roll, towards the Summit 910. The flanged coupling must be on the right side of the feed shaft, as viewed from the front of the Summit 910.

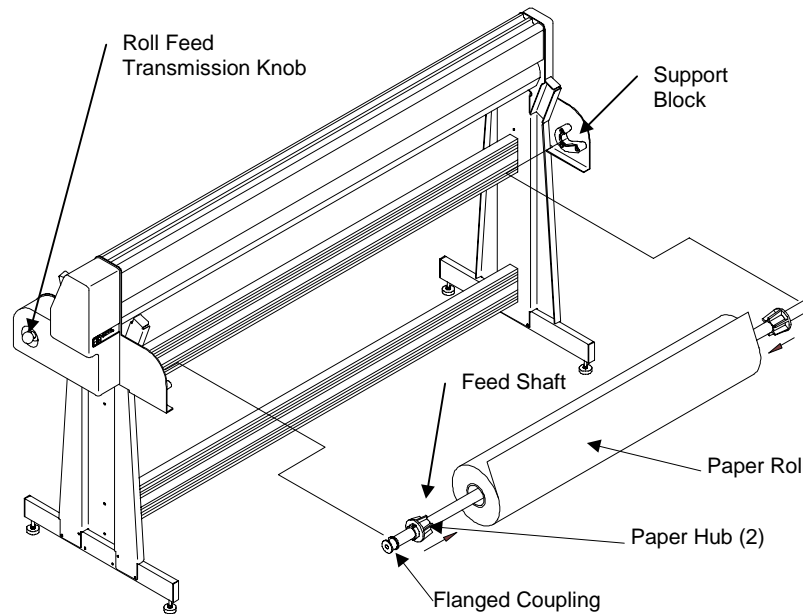

Figure 12. Installing the Feed Shaft (rear view)

4. Center the paper roll between the two stand end plates by sliding it to the left or right along the feed shaft. Make sure the hubs remain securely in place.
5. Use the hex wrench to tighten the screws on each paper hub.
6. Before installing the takeup shaft, pull out the roll feed transmission knob.
7. Put the roll feed takeup shaft onto the front takeup shaft support blocks, with the flange coupling at the right end.

8. Rotate the right end of the takeup shaft while you push in the roll feed transmission knob. This will enable you to align the takeup shaft engagement pin with the roll feed transmission shaft slot. When the shaft slot and the engagement pin are aligned, push the roll feed transmission knob all the way in.

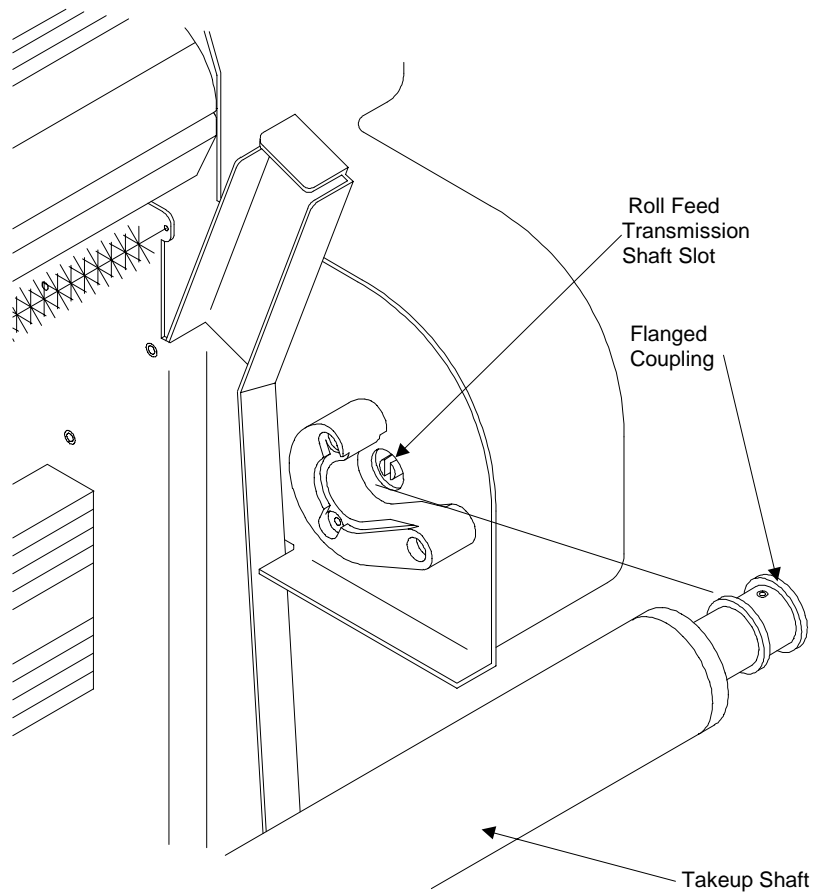

Figure 13. Aligning the Shaft Slot and the Engagement Pin

9. If the chartwheels are lowered, raise them by lifting the chartwheel lever on the right side of the Summit 910.

10. Turn on the Summit 910 Marker Plotter.
11. Pull some paper off the paper roll and feed it over the platen and under the raised chartwheels.

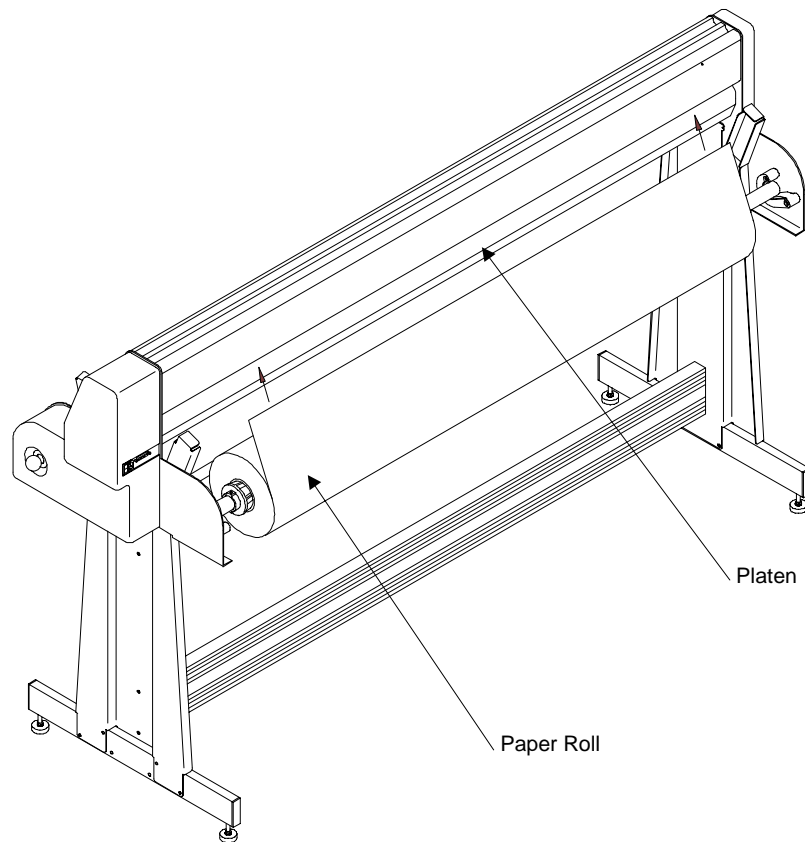

Figure 14. Pulling Paper off the Paper Roll

12. Use both hands to pull the paper down over the front of the Summit 910 to the takeup shaft.

Important: The following steps are critical to producing good quality marker plots.

! Make sure the paper is even, taut, and square as you pull it off the paper roll.

Note: The takeup shaft must be completely free of paper before you install a new paper roll. To remove any remaining paper from the takeup shaft, make sure the Summit 910 is in Stop mode (red light on) and then press the roll feed key up arrow to unroll the paper onto the floor.

13. Tape the middle of the front edge of the paper to the center of the takeup shaft. Then tape the front edge of the paper to the takeup shaft in four additional places, in the following order:
 - A. At the left edge of the paper
 - B. At the right edge of the paper
 - C. Halfway between the center of the paper and the right edge of the paper
 - D. Halfway between the center of the paper and the left edge of the paper

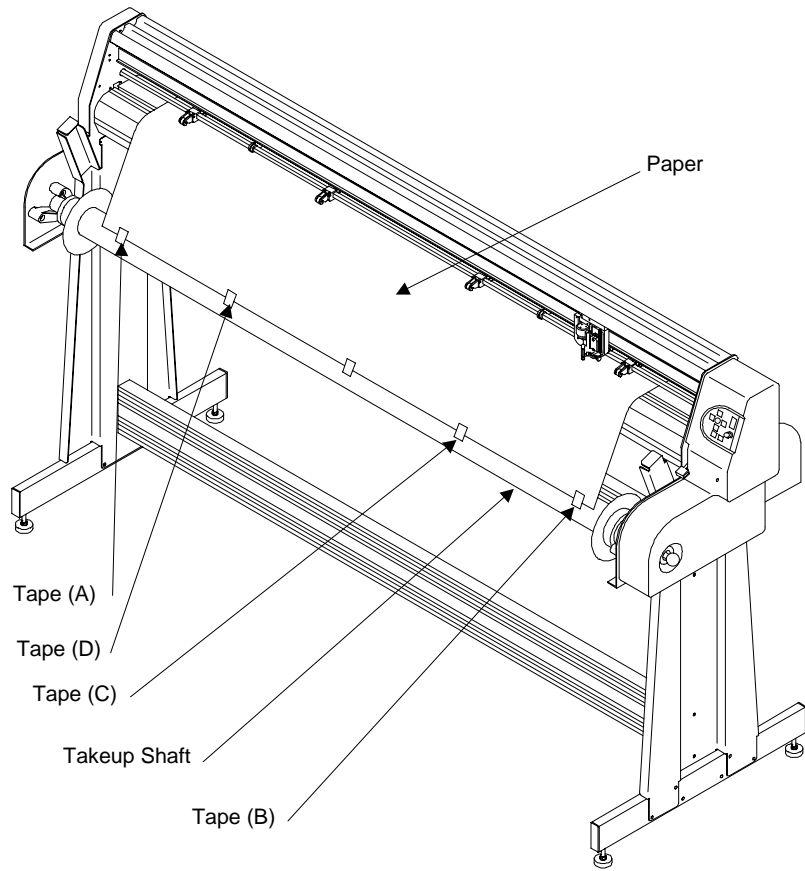

Figure 15. Taping the Paper to the Takeup Shaft

! The paper must be taut and square all along the paper path, from the feed shaft paper roll over the platen to the takeup shaft.

14. Press the roll feed key down arrow to pull some paper off the feed roll, until the paper wraps around the takeup shaft two or three times.
15. There are six chartwheels mounted on the chartwheel shaft. Position the outermost pair of chartwheels six inches (15 cm) in from the outer edges of the paper.

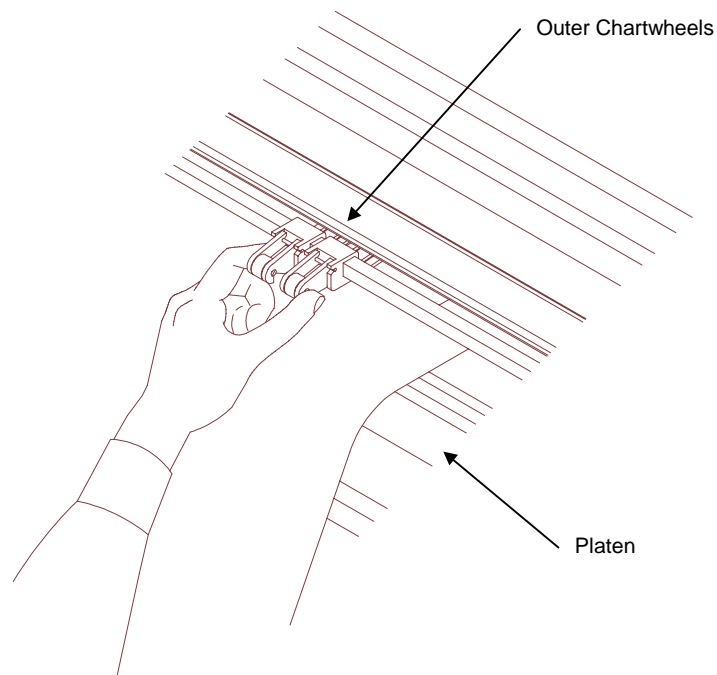

Figure 16. Positioning the Outer Chartwheels

16. The two remaining chartwheels should be evenly spaced along the width of the paper. Slide the two inner chartwheels to positions that result in an even spacing (See Figure 17).
17. Make sure the paper is taut and square in front and in back of the Summit 910.
18. Clamp the chartwheels to the paper by lowering the chartwheel lever on the right side of the Summit 910.
19. Drop the dancer bars into the dancer bar channels.

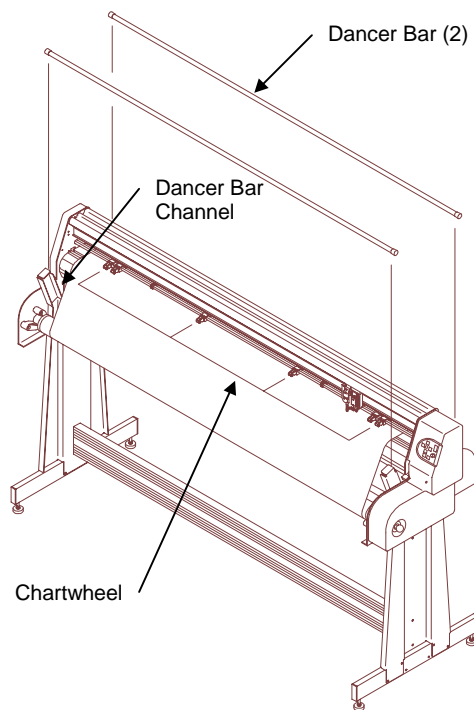

Figure 17. Installing the Dancer Bars

20. Make sure a pen is installed in the pen holder. Then press the left or right arrow keys to move the pen carriage to the place along the Y-axis that you want to use as the starting point for your next marker. Then press the Start Point key. If you do not move the pen carriage to a new position and press the Start Point key, the Summit 910 will use the previous starting point for your next marker plot.

Note: Before you press the keypad Start Point key, make sure the paper is taut between the paper roll and the plotter. There should be no feed loop at all in back of the plotter.

21. When you press the Start Point key, the Summit 910 will use the position of the pen carriage as the starting point of your next marker. The Summit 910 will then create a measured feed loop, the length of the plotter's page length setting. The factory set page length is 46 inches (116.9 cm). The Summit 910 Marker Plotter will then switch to Start mode (green light on) and be ready to accept a marker plot file from your computer.
22. Check the paper path against Figure 18 for proper installation.

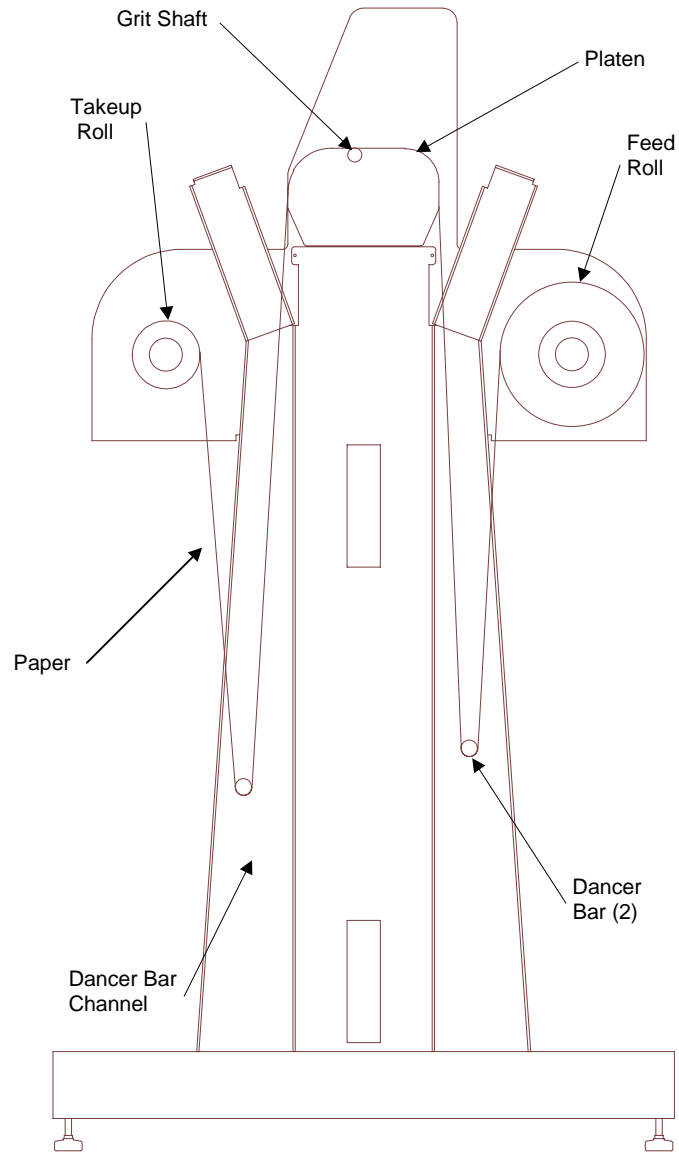

Figure 18. The Paper Path

3 OPERATING THE SUMMIT 910

FRONT PANEL CONTROLS

When the entire system is assembled, connected, and ready to go, take a few moments to familiarize yourself with the controls on the front panel. If you encounter a problem simply stop and review all the steps to see if you have left something out. If you still have problems, refer to the Troubleshooting section on page 61.

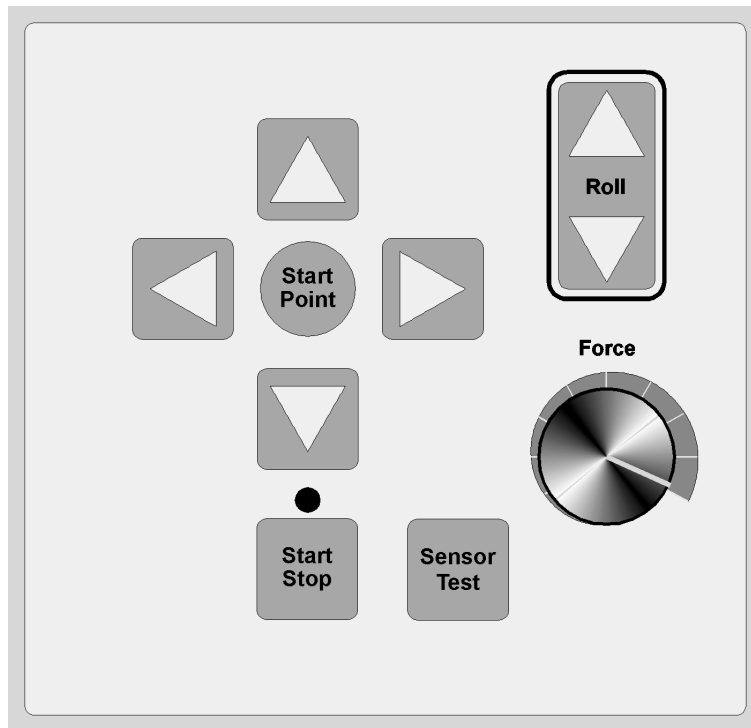

Figure 19. The Summit Marker Plotter Control Panel

Start/Stop

Pressing this key causes the Summit 910 to alternate between two states: either communicating with the computer (Start) or not communicating with the computer (Stop). You may want to use the Start/Stop key while you are testing the unit or to set up the Summit 910 before you begin plotting a marker. If you press the Start/Stop key during the plotting of a marker, the Summit 910 will stop.

When the Summit 910 is in Stop mode, the red light will be on. In Stop mode, the keypad of the Summit 910 is enabled and you will be able to use the arrow keys to move the pen and the paper. If you press the Start/Stop key again, the Summit 910 will return to the place where it stopped and resume plotting. **Never press the keypad Roll keys when the Summit 910 is stopped during plotting: the Summit 910 will not be able to continue plotting from where it was stopped.**

When the Summit 910 is in Start mode, the green light will be on. In Start mode, your computer can communicate with the Summit 910 and the keypad of the Summit 910 is disabled, except for the Start/Stop key.

Arrow Keys

The arrow keys move the paper back and forth in the X-axis and the pen carriage left and right in the Y-axis within a frame. Make sure the Summit 910 is in Stop mode and then use the arrow keys to move the paper forward or back or the pen carriage from side to side. The arrow keys control paper and pen carriage movement within the parameters of the Summit 910's frame setting. If the frame length setting is 46 inches, the up and down arrow keys will be capable of moving the paper in relation to the pen carriage 46 inches from the top of the frame to the bottom of the frame. If you want to move the paper outside the frame, refer to the Roll Feed key description.

The longer you press any of these arrow keys, the greater the speed of the movement. To move diagonally, press two arrow keys simultaneously.

Start Point

Note: Before you press the keypad Start Point key, always make sure the paper is taut between the paper roll and the plotter. There should be no feed loop at all in back of the plotter.

The Start Point key is used to set the point on the paper at which the Summit 910 will start plotting a new marker. Use the arrow keys to move the pen carriage to the place on the paper where you want to start your next marker, then press the Start Point key. The Summit 910 will create a measured feed loop, the length of the page frame X-axis setting. The factory set page frame length is 46 inches. The Summit 910 will then switch to Start mode and be ready to accept a marker plot file from your computer.

Pen Force

The Pen Force setting adjusts the pen's downward pressure on the paper. You can set the force by using the dial on the front panel. You can set the minimum and maximum values of the force dial from the Control Center. The correct force depends on the type of pen you are using. If your force setting is too high, the pen may tear the paper.

Roll Keys

Use the Roll keys to control the movement of the takeup shaft and the movement of the paper while loading or unloading paper, before or after plotting. Never use the Roll keys when the Summit 910 is stopped during plotting. The Summit 910 must be in Stop mode (red light on) when you use the Roll keys. You can use the Roll key down arrow to pull paper off the feed roll. You can use the Roll key up arrow to unroll a completed marker plot onto the floor. In Stop mode, the Roll key up arrow causes

the takeup shaft to unroll the completed marker slowly at first, then the takeup shaft speeds up.

Sensor Test

If you press the keypad Start/Stop key to put the Summit 910 in Stop mode and then press the Sensor Test key, the Summit 910 will beep once. This indicates that the Summit 910 does not have a frame sensor. The functionality of the Summit 910 Sensor Test key is limited to diagnostic testing. See Chapter 7, Testing and Troubleshooting.

4 SENDING AND CANCELING MARKER PLOT FILES

SENDING A MARKER PLOT FILE

When you have completed an apparel design pattern on your computer, send the pattern (as a marker plot file) to the Summit 910. However, before you send the marker plot file to the Summit 910, make sure the plotter is on and the paper is loaded. Also, be sure to press the Start Point key to place the Summit 910 in Start mode (green light on).

From Your Apparel Design Software

In most cases you will use your apparel design software to create a marker plot file and then send the completed file directly to the Summit 910. If you use this method, be sure to follow the apparel design software's instructions for sending the completed marker plot file to a plotter. The Summit 910 will receive the marker plot file and proceed to draw the pattern that you have created.

From the Ioline Control Center

You may choose to use the Ioline Control Center software to send a completed marker plot file to the Summit 910. To do this you must first make sure you know the name and path of the marker plot file. Open the Summit 910 Control Center main menu, as described in Chapter 6 of this user's guide.

1. Select FILE.

2. Select SEND PLOT FILE.

Enter the correct path and the name of the file that you want to send to the Summit 910. For example, your path might be:

C:\WSCC*(filename)*

CANCELING A MARKER PLOT

From Your Apparel Design Software

1. Press the Start/Stop key to place the Summit 910 in Stop mode (red light on).
2. Cancel the plot from your apparel design software (refer to your apparel design software manual or consult your software dealer).
3. Press the Start Point key to make the Summit 910 clear its buffer and forget the plot data it has already received but has not yet drawn.

Note: Before you press the Start Point key, make sure the paper is taut between the feed shaft and the plotter.

From the Ioline Control Center

1. Select ABORT from the Control Center screen.
2. Press the Start/Stop key to place the Summit 910 in Stop mode (red light on).
3. Use the arrow keys to move the pen carriage to the position on the paper you want to use as the starting point..

Note: Make sure the paper is taut between the feed shaft and the plotter, then press the Start Point key to clear the buffer. This will cause the Summit 910 to forget the plot file it has already received, but has not yet drawn.

5 THE IOLINE CONTROL CENTER

The Ioline Control Center is a program that comes on a diskette with the Summit 910. It does three things:

- It allows you to adjust a variety of settings that you can use to specifically tailor output from your computer.
- It allows you to send a completed plot file to the Summit 910.
- It has several diagnostic tests for troubleshooting.

INSTALLING THE IOLINE CONTROL CENTER

The Summit 910 comes with a single 3.5" diskette, which contains the entire Ioline Control Center program. Both Windows 3.x and DOS versions of the program are on the diskette. The Macintosh version of the program is available from your dealer. Use the diskette that is appropriate for your computer. Read the installation procedure that applies to the type of computer environment from which you are going to communicate with the Summit 910.

With the Windows and DOS versions of the Ioline Control Center program you can use either a mouse or the keyboard of your computer to change the factory plotter settings. If you use the keyboard, note the following general rules:

- Use the **Tab** key to cycle through the settings fields.
- Use either the **up/down** cursor movement keys or the **numeric** keys to change a numeric value within a highlighted settings field.
- Use the **Alt** key to toggle between the pull down menus.

- Use the **space bar** to toggle check boxes on and off.
- Use the **Enter** key to select a highlighted field.

Windows Installation

Install the Ioline Control Center (on a computer that is running Windows) in the following manner:

1. Turn on your computer and the Summit 910. Make sure the Summit 910 is in Start mode (green light on).
2. Start Windows on your computer.
3. From the Windows Program Manager select FILE.
4. Select RUN.
5. Insert the Ioline Control Center diskette into the floppy disk drive of your computer.
6. Now type (depending on the letter assignment of the diskette drive you are using) either,

A:SETUP

or

B:SETUP

7. Follow the instructions that appear on your screen. When the Windows installation is complete, double click on the Control Center icon. The Control Center Setup Screen will appear. Select SUMMIT 910 and the communication port that you are going to be using to send marker plot files to the plotter. Com2 is the factory set communication port selection.

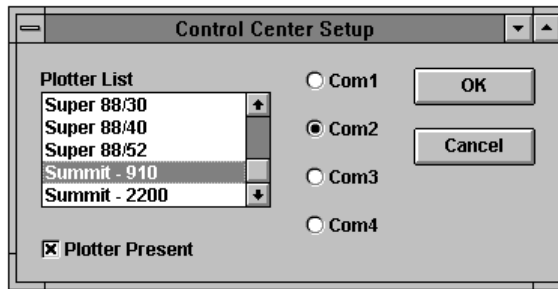

Figure 20. Control Center Setup Screen

- 8. Select PLOTTER PRESENT and select OK. You will see the Control Center Main Menu.

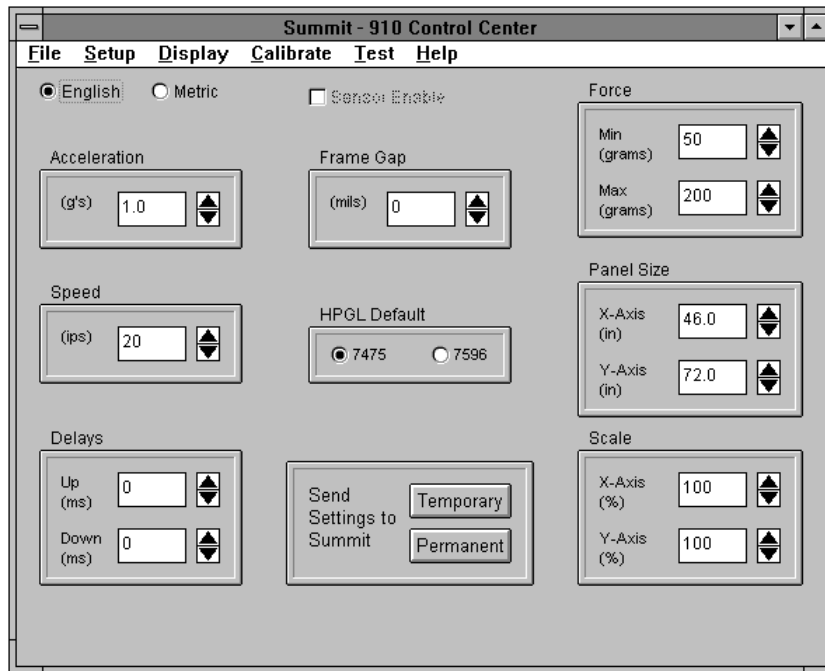

Figure 21. Control Center Main Menu

DOS Installation

To install the Ioline Control Center on a DOS compatible computer, we recommend that you have the following hardware installed on your computer:

- One floppy disk drive (3.5" - high density)
- A hard disk drive
- A graphics adapter card (either Hercules compatible, EGA, or VGA)
- A mouse (optional)

Install the Ioline Control Center program in the following manner:

1. Turn on your computer and the Summit 910. Make sure the Summit 910 is in Start mode (green light on).
2. Insert the Ioline Control Center diskette into the floppy disk drive of your computer.
3. Your computer screen should say this:

```
C:\>
```

Now type (depending on the letter assignment of the diskette drive you are using) either,

```
A: INSTALL <Enter>
```

or

```
B: INSTALL <Enter>
```

5. Follow the instructions that appear on your screen. The Ioline Control Center program will install itself in a sub-directory (called SCC) on your hard disk.

6. When the installation is finished, reboot your computer by simultaneously pressing the **Ctrl**, **Alt**, and **Del** keys on your keyboard. This will complete the installation procedure by placing the SCC sub-directory in your computer's path.
7. Now type,

CD\SCC <Enter>

You have entered the special sub-directory for the Control Center.
8. Now type,

SCC
9. Select SUMMIT 910 and the communication port that you are going to be using to send marker plot files to the plotter. Com2 is the Factory set communication port selection.
10. Select PLOTTER PRESENT.
11. Select OK.

Macintosh Installation

Note: You cannot run the Macintosh version of the Control Center from a floppy disk. You must install the software to a hard drive before you will be able to run it.

Install the Ioline Control Center on a Macintosh computer in the following manner:

1. Turn on your Macintosh computer and the Summit 910. Make sure the Summit 910 is in Start mode (green light on).
2. Insert the Macintosh version of the Control Center diskette into the floppy disk drive of your computer.

3. Double click on the Ioline Control Center Installer icon.
4. Follow the instructions that appear on your screen. An Ioline folder will be created on your hard disk.
5. Double click on the Ioline folder.
6. To start the Control Center program, double click on either the PowerMacSCC icon or the MacSCC icon, depending on the type of Macintosh computer you are using.

CHANGING YOUR SYSTEM SETTINGS

The Summit 910 must be in the Start mode when you change system settings. Press the Start/Stop key and make sure the green light is on before you change any settings.

Look at the main menu screen. You will see that the Settings line is highlighted. This menu selection is what you will use to change a variety of settings for the Summit 910.

Note: You will probably never need to change any of the factory settings. However, we have provided you with the ability to customize a variety of settings to fit your exact needs.

English or Metric Measurement Units

You have a choice of using English or Metric settings.

Acceleration

The factory acceleration setting is 1 g. The acceleration setting determines how quickly the pen will reach full speed when starting or ending a marker line. A higher setting will increase the Summit 910's throughput, but may lower the quality of your marker. You can use the Control Center to change the acceleration setting within a range of 0.1 to 2.0 g. Normally, you will not adjust this setting.

Speed

The factory setting for speed is 20 inches per second (51 cm/sec). A lower speed may improve the quality of your marker, but will decrease the Summit 910's throughput. From the Control Center you can set the speed from 1 to 20 inches per second.

Up/Down Delays

The factory set up and down delays are 0 milliseconds. This means that the Summit 910 pen will instantly rise from the paper at the end of each segment of the marker. The pen will also instantly lower to the paper at the end of each segment of the marker. A longer up or down delay setting will make the pen move more slowly and slow throughput, but it may also improve the quality of your marker. From the Control Center you can set the delays from 0 to 250 milliseconds.

Adjusting the Frame Gap

You may want to adjust the size of the frame gap between adjacent frames. If adjacent frames of marker plots are overlapping, you should enter a positive number in the frame gap field of the Control Center screen. If there is space between frames, you should enter a negative number in the frame gap field of the Control Center screen. You can adjust the frame gap from -1000 mils to +1000 mils (-25.4 mm to +25.4 mm). To determine the frame gap setting:

1. Send a marker plot with at least two frames to the Summit 910.
2. After the plot has been completed, examine and measure the frame gap or overlap.
3. If you want to increase the distance between adjacent frames and create a larger frame gap, enter a positive number in the frame gap field on the Control Center screen.

If you want to reduce the distance between frames and create a smaller frame gap, enter a negative number in the frame gap field on the Control Center screen.

4. From the Control Center screen, select SEND SETTINGS TO SUMMIT: Temporary or Permanent.

HPGL 7475 or 7596 Plotter Language/DMPL

The Summit 910 supports three industry standard plotter languages: HPGL 7475, HPGL 7596, and DMPL. The Summit 910 will automatically switch from DMPL to HPGL (7475 or 7596) and vice versa. If your apparel design software uses HPGL, you must select the version (7475 or 7596) of HPGL that your software uses. If your apparel design software uses either version of HPGL, the software frame size setting must be identical to the Control Center frame size setting. If your apparel design software uses DMPL, the software frame size setting must be less than or equal to the Control Center frame size setting.

HPGL 7475 is the factory set plotter language. It has a lower left origin. A lower left origin means that the starting point you set on the Summit 910, where plotting begins, is the lower left point of the marker.

The Summit 910 also supports HPGL 7596. This is a plotter language with a center origin. A center origin means that the Summit 910 begins plotting from the center of the frame and measures everything from this location.

Force

You can select a force setting range from 1 to 300 grams. From the Control Center, you can set the minimum and maximum limits for the force dial. The factory set minimum is 50 grams. The factory set maximum is 200 grams. If you select a narrow range of values, you can use the Force dial to make fine

adjustments to the force setting. If you select a wide range of values, you can use the Force dial to make coarse adjustments to the force setting.

Panel Size

Your apparel design software can create long markers by dividing them into smaller, more manageable frames. The Summit marker plotter's factory set maximum frame size is 46 inches long by 72 inches wide.

Scale

The factory set scale is 100%. The Summit 910 will produce a marker in the exact size of any marker file that you send. If you set the scale to 50%, the Summit 910 will produce a marker that is half the size of any marker file that you send. You can set the scale of the Summit 910 from 1% to 999%.

Set Factory Settings

If you want to send the factory settings to the Summit 910, select DISPLAY from the Control Center main menu, then select FACTORY DEFAULTS. The Control Center will ask if you want to update the Summit 910. If you select OK, the settings are sent to Summit 910 temporarily.

Send Settings to Summit 910: Temporary

After you have changed any setting, you must send the changes to the Summit 910. If you choose this menu selection, the Summit 910 will use the new settings. You may also save your settings to a file and send them to the Summit 910 at a later time. Select FILE from the main Control Center menu to use this option. When you turn off the Summit 910, these settings will be lost and the previous settings will be in effect when you turn on the Summit 910 again.

Send Settings to Summit 910: Permanent

If you choose this menu selection, all of the displayed settings will be sent to the Summit 910 and they will be saved for all subsequent sessions, even after you turn off the Summit 910.

Calibrate

The purpose of the calibrate section of the settings menu is to generate and then measure a calibration plot so you can test the accuracy of the X-axis and Y-axis measurements produced by the Summit 910[†]. You can then adjust the Summit 910 for increased accuracy.

1. Load some paper into the plotter.
2. From the Control Center main menu, select CALIBRATE, then select CALIBRATE PLOTTER. Now select CALIBRATION PLOT. The Summit 910 will draw a box onto the paper, 40 inches long by 30 inches wide (101 cm by 116 cm).
3. Precisely measure the X-axis (length) and the Y-axis (width) of the box and enter the measured X-axis and Y-axis values.
4. Select SET CALIBRATION.
5. If you want to restore the factory set X-axis and Y-axis values, select RESET CALIBRATION.
6. Select DONE. The Summit 910 is now recalibrated.

[†] The X-axis is the direction that the paper moves; the Y-axis is the direction that the pen moves.

6 PREVENTIVE MAINTENANCE

You should perform the following preventive maintenance procedures, as required. Before you can perform some of these procedures you will have to remove the dust cover.

CLEANING THE GRIT SHAFT

Note: Any dust and paper residue that accumulates on the grit shaft or under the chartwheels can cause the grit shaft to lose contact with the paper, which may result in a slippage of the paper during plotting.

You will need to clean the grit shaft regularly to make sure the Summit 910 continues to draw accurate marker plots. Clean the grit shaft in the following manner:

1. Turn off the Summit 910.
2. Remove the paper from the platen.
3. Using the grit shaft cleaning brush, remove any accumulated dust and paper residue from the grit shaft.

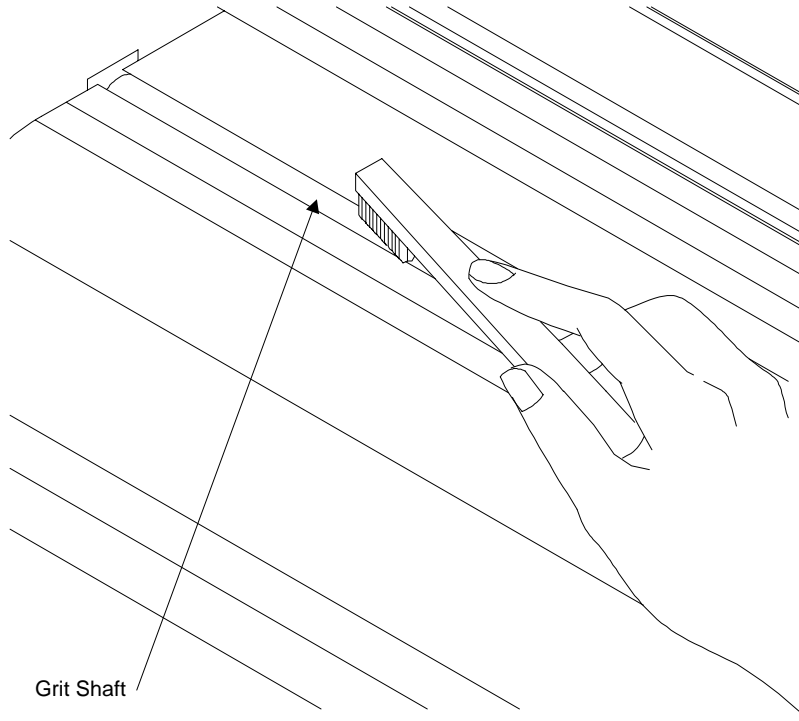

Figure 22. Cleaning the Grit Shaft

CLEANING THE PLATEN

As you use the Summit 910, dust and paper residue will accumulate on the platen. You may have to remove this accumulated dust and paper residue as often as every two weeks. Clean the platen by wiping with an isopropyl (pharmacy) alcohol dampened, lint-free cloth. Or you may prefer to use a commercially available anti-static spray instead of isopropyl alcohol to clean the platen. Clean the platen in the following manner:

1. Turn off the Summit 910.
2. Dampen a lint-free cloth with isopropyl (pharmacy) alcohol and gently wipe the platen until any accumulated residue has been removed. You may choose to use anti-static spray instead of isopropyl alcohol to clean the platen.

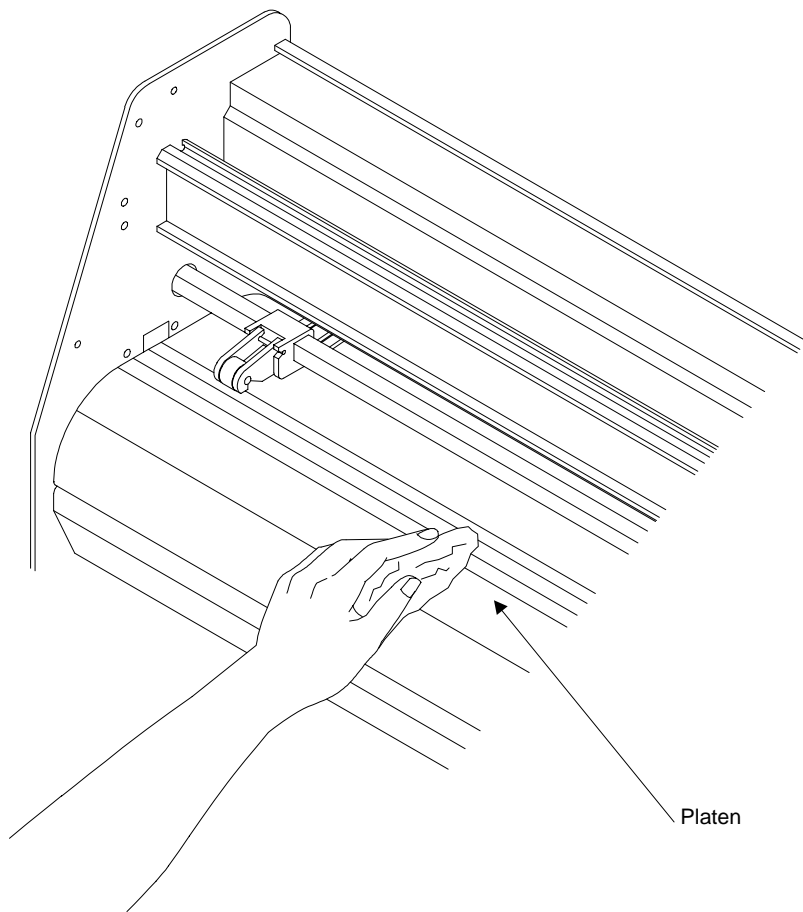

Figure 23. Cleaning the Platen

CLEANING THE SUPPORT BLOCKS

Dust and paper residue will accumulate on the takeup and feed shaft support blocks. Clean the support blocks by wiping them off with an isopropyl (pharmacy) alcohol dampened, lint-free cloth. Clean the support blocks in the following manner:

1. Turn off the Summit 910.
2. Disengage the transmission by pulling out the transmission knob.
3. Remove the feed shaft and the takeup shaft.
4. Dampen a lint-free cloth with isopropyl (pharmacy) alcohol and gently wipe the support blocks until any accumulated residue has been removed.
5. Wipe down the ends of the feed shaft and the takeup shaft before you re-install them.

Note: The remaining preventive maintenance procedures require the removal of the dust cover. Proceed to the dust cover removal procedure on the next page.

REMOVING THE DUST COVER

1. Turn off the Summit 910 and unplug all of the cables.
2. Remove the transmission knob and the right cover, as described on page 14.
3. Remove the three black, flat head screws that hold the left cover to the Summit 910, then remove the left cover.
4. Use a screw driver to remove the two dust cover screws, one from each end of the Summit 910. Make sure you remove only the two dust cover screws (refer to Figures 24 through 26).
5. Remove the dust cover.

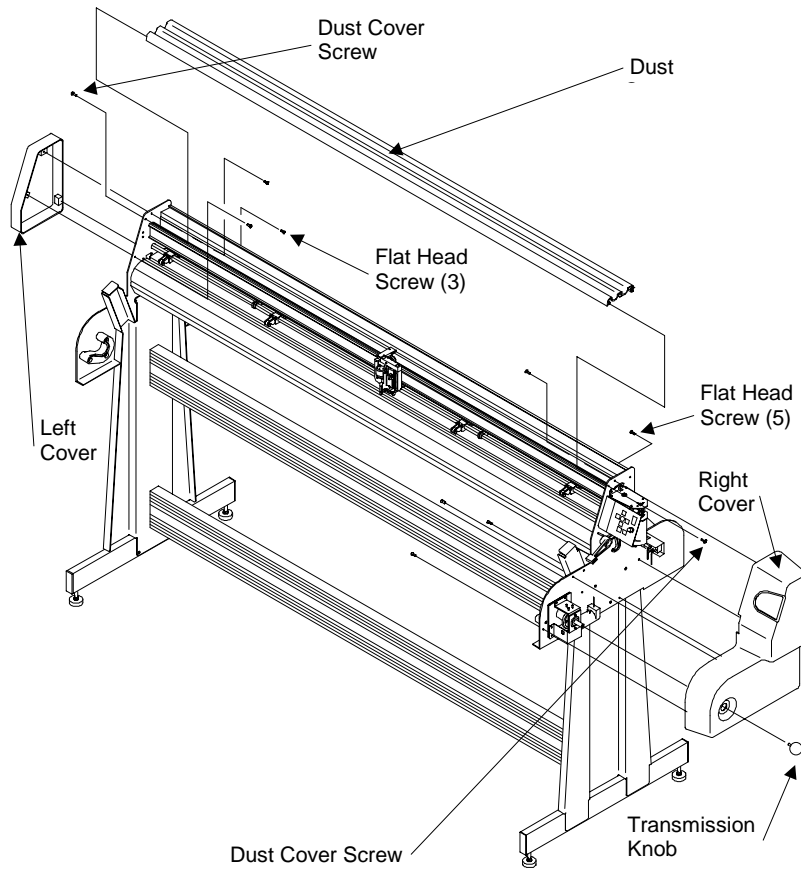

Figure 24. Removing the End Covers and the Dust Cover

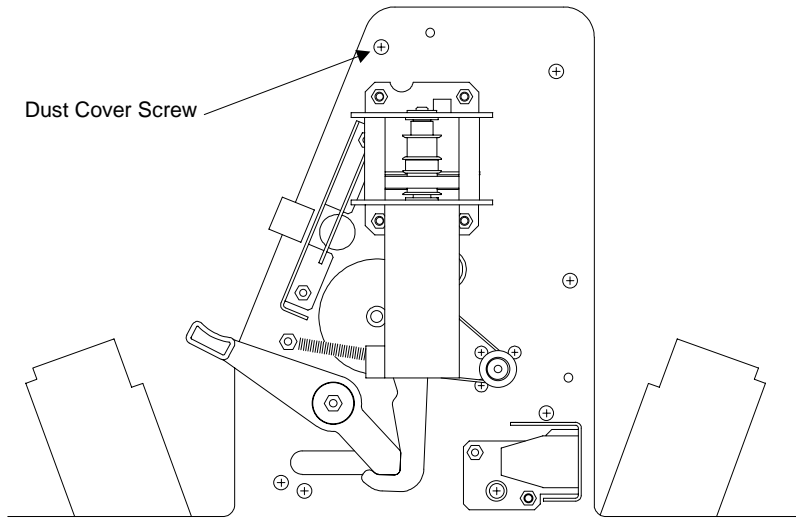

Figure 25. Right End With Cover Removed

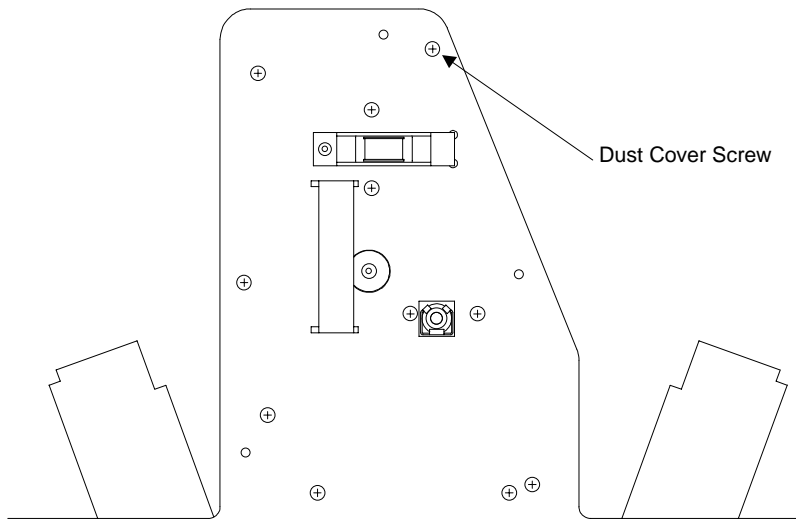

Figure 26. Left End With Cover Removed

CLEANING THE TRAVERSE EXTRUSION AND CARRIAGE V-WHEELS

As dust and debris accumulate on the traverse extrusion, you will have to wipe it off with an isopropyl (pharmacy) alcohol dampened, lint-free cloth. Clean the traverse extrusion and the carriage v-wheels in the following manner:

1. Remove the dust cover if you haven't yet (refer to the Removing The Dust Cover procedure above).
2. Dampen a lint-free cloth with isopropyl (pharmacy) alcohol and gently wipe the top and bottom rails of the traverse extrusion until any accumulated dust and debris has been removed.
3. Carefully lift the ribbon cable from the groove. Do not unplug the ribbon cable. Gently wipe the ribbon cable groove and remove any accumulated dust and debris.
4. Clean the carriage v-wheels by holding an isopropyl alcohol dampened lint-free cloth against a v-wheel while you gently slide the carriage back and forth. Repeat this procedure for each of the v-wheels.
5. Reinstall the dust cover.

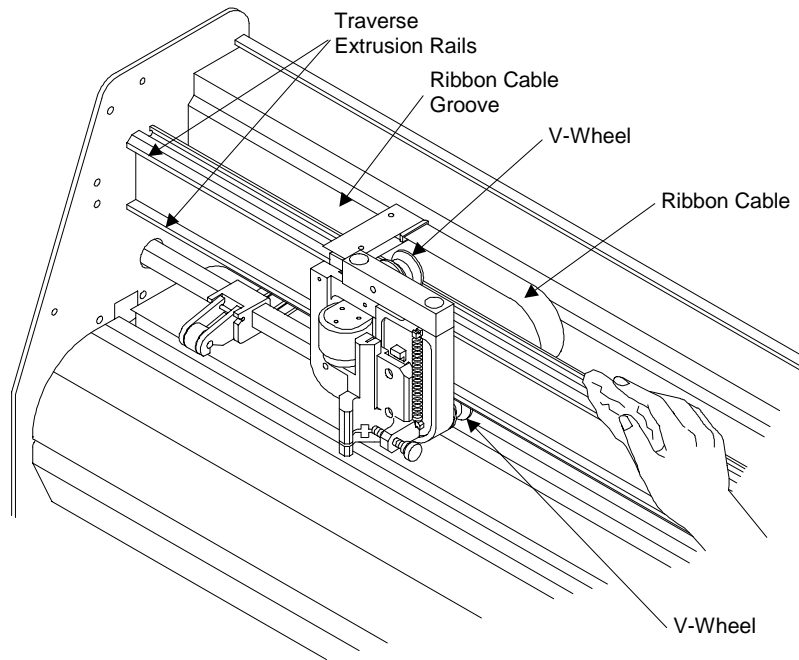

Figure 27. Cleaning the Traverse Extrusion and Carriage V-Wheels

7 TESTING AND TROUBLESHOOTING

DIAGNOSTIC TESTING

There are three diagnostic tests that you can run from the Control Center. These tests are designed to help you determine if you are having a communications problem and isolate where the problem is occurring.

To run two of these tests, you will have to connect the diagnostic module (available from your dealer) to either your computer's serial port or to the Summit 910's serial port. The diagnostic module is a tool that you can use to determine whether there is a problem with either serial port. You won't need to use the diagnostic module for the first of these tests.

Testing The Summit Marker Plotter/Computer Communications

Run this test from the Control Center. You will not need to use the diagnostic module to run this test.

1. Connect one end of the cable to the serial port on the Summit 910 and the other end of the cable to your computer's serial port.
2. From the Control Center screen, select TEST.
3. Select SERIAL TEST.
4. Turn on the Summit 910 while you hold down the Sensor Test key on the keypad. Hold down the Sensor Test key until the Summit 910 beeps and the lights flash three times.
5. Press the Start/Stop key on the Summit 910 and verify that the handshake line (CTS) displayed on your computer screen toggles ON/OFF. Leave the handshake lines ON.

6. Press the roll feed up arrow key to switch the Summit 910 into ECHO mode. The green light will come on.
7. Press any key on your computer keyboard and verify that the character transmitted equals the character received. If the Summit 910 and your computer pass all of these tests, you should not have any problems producing accurate plots from your marker plot files.
8. Select EXIT after completing the serial test.
9. **Turn off the Summit 910 at the end of the test.** This will restore normal communications between the Summit 910 and your computer.
10. If this test is successful, you do not need to perform the next two tests.

Testing The Summit Marker Plotter PortError! Bookmark not defined.

Connect the diagnostic module directly to the Summit 910 serial port.

1. From the Control Center screen, select TEST.
2. Select PLOTTER PORT TEST.
3. Turn on the Summit 910 while you hold down the Sensor Test key on the keypad. Hold down the Sensor Test key until the Summit 910 beeps and the lights flash three times.
4. Press any arrow key to transmit and receive characters. Verify that Summit 910 beeps and the green light flashes.
5. **Turn off the Summit 910 at the end of the test.** This will restore normal communications between the Summit 910 and your computer.

Testing Your Computer Port

Use the DOS MODE command to install the communications settings. For example, to install serial port 2 type:

```
MODE COM2:96,N,8,1,P
```

Connect the diagnostic module directly to the serial port on your computer.

If your computer's serial port has a 9 pin connector, you will need to use a nine to 25 pin adapter between the serial port and diagnostic module.

1. From the Control Center screen, select TEST.
2. Select COMPUTER PORT TEST.
3. Verify the COM port displayed is the correct one.
4. Press any key on the computer keyboard and verify that the character transmitted is the same as the character received.

TROUBLESHOOTING

If your system isn't working correctly, your first job is to figure out which component is causing the problem. The problem could be with your computer, your cable, your apparel design software, or with the Summit 910. First make sure the cable between your Summit 910 and your computer is connected correctly. Make sure the power is on. If the problem is with your computer or your apparel design software, consult your computer or software manuals. If you still can't solve the problem, call the appropriate manufacturer or dealer.

If the problem is with the Summit 910, consult the following Troubleshooting Chart. If you are sure the problem is with the Summit 910 and you can't find a solution in this user's guide, contact your dealer.

TROUBLESHOOTING CHART

If your marker plot doesn't start at the correct point on the paper:

<u>Possible Cause</u>	<u>Solution</u>
You haven't set the starting point.	Set the starting point.

If you've sent a marker plot file, but nothing happens:

<u>Possible Cause</u>	<u>Solution</u>
A communication problem.	Make sure the serial ports on your computer and the Summit 910 are set properly.
The Summit 910 is in Stop mode.	Press the Start/Stop key to put your Summit 910 in Start mode (green light on).

If you've sent a marker plot file, and the output is erratic:

<u>Possible Cause</u>	<u>Solution</u>
You've sent your marker plot file with the wrong plotter language setting.	Make sure your apparel design software and the Summit 910 are set to the same plotter language (either HP7475 or HP7596).

If the front panel green light displays a cycle of a double blink followed by a brief pause and the Summit 910 is beeping:

<u>Possible Cause</u>	<u>Solution</u>
The maximum capacity of the takeup shaft (10 yards or 9.1 meters) has been reached.	Remove completed markers from the takeup shaft. You can press the Start/Stop key twice to continue plotting an additional frame, but frame alignment accuracy will degrade if you exceed 10 yards (9.1 meters) of completed markers on the takeup shaft. After you remove the completed markers from the takeup shaft and reload the paper onto the Summit 910, press the Start Point key.

If the pen skips or tears the paper:

<u>Possible Cause</u>	<u>Solution</u>
The pen is improperly loaded.	Reload the pen.
The pen is dry.	Replace the pen.
The pen tip is broken.	Decrease the pen force and replace the pen.
Dirt or debris is stuck on the pen.	Clean or replace the pen.

If the corners of the lines on your completed markers are not completely meeting:

<u>Possible Cause</u>	<u>Solution</u>
The paper is slipping.	Clean the grit shaft (refer to the Cleaning the Grit Shaft procedure).
The pen force setting is too low.	Increase the pen force.

If the Summit 910 does not complete the marker, leaving a large gap between frames:

<u>Possible Cause</u>	<u>Solution</u>
Your apparel design software frame size is set larger than the Summit 910's frame size setting (the factory set and maximum frame size is 46 inches).	Increase the Summit 910's frame size setting (from the Control Center) to match the setting of your apparel design software (or lower your apparel design software's frame size setting to match the Summit 910).

If the front panel red light displays a cycle of a single blink followed by a brief pause:

<u>Possible Cause</u>	<u>Solution</u>
The grit shaft is jammed.	Turn off the Summit 910 and clear away any debris or jammed paper.

If the front panel green light displays a cycle of a single blink followed by a brief pause:

<u>Possible Cause</u>	<u>Solution</u>
The carriage of the Summit 910 is jammed.	Turn off the Summit 910 and clear away any debris or jammed paper.

If the front panel red light displays a cycle of a double blink followed by a brief pause:

<u>Possible Cause</u>	<u>Solution</u>
Buffer overflow - communication problem.	Perform the tests on page 59. Call your dealer.

If the front panel light is blinking red and green alternately:

<u>Possible Cause</u>	<u>Solution</u>
Plotter language syntax error.	Make sure your software and your Summit 910 are set to the same plotter language (HP-7475, HP-7596, or DM/PL).

No Power When You Turn on the Summit 910

If the fan does not go on when you turn on the Summit 910, verify that the power cord is properly attached to the Summit 910 and plugged into a functional electrical outlet.

The Summit 910 Won't Respond to Your Computer

If you have trouble getting the Summit 910 to accept commands from your computer, perform these procedures:

- Verify that the communications cable is correctly connected to the Summit 910 and to the proper communications port on your computer.
- Check to see that the computer COM port that you are using is configured to match the Summit 910's serial COM port settings.
- Make certain that the marker file and the Summit 910 are set to the same plotter language.
- You may have to perform the diagnostic testing procedures described on page 58.

Loss of Registration Within a Frame

Loss of registration occurs when the paper has slipped during plotting. The underside of your completed marker plot will always have six visible grit tracks where the chartwheels hold the paper against the grit shaft. The chartwheel pressure on the grit shaft creates an impression on your marker. The grit tracks should be identical.

If one grit track is more pronounced than the others, or if one grit track has a markedly different pattern than the others, this may be an indication of loss of registration.

You may be able to correct a loss of registration problem by reducing the speed setting from the Control Center. Before you adjust any settings, consider these possibilities:

- The paper may have been loaded incorrectly. Be sure to pull the paper taut and square before lowering the chartwheels.
- The paper may be sticking to the platen because the platen may be dirty. Inspect the platen and refer to the Cleaning the Platen section of Chapter 6 of this user's guide.
- The paper may be slipping because debris may have accumulated in the grit shaft, preventing the grit shaft from properly gripping the paper. Inspect the grit shaft and refer to the Cleaning the Grit Shaft section of Chapter 6 of this user's guide.
- Inspect the paper for wrinkles or folds. Never use any paper that is folded, wrinkled, or torn in any way. Allow the paper to stabilize (temperature and humidity) at least one day prior to plotting.
- Make sure the outermost chartwheels are at least six inches (15 cm) in from the edge of the paper.

Loss of Registration Between Frames

If you observe a degrading of the frame to frame accuracy of your completed marker plots, this may indicate a loss of registration between adjacent frames. You may be able to correct this problem by reducing the speed and acceleration settings from the Control Center. The frame size length setting may also be set too high. Try reducing the frame size length setting from the Control Center. Before you adjust the speed, acceleration, or frame size settings, consider these possibilities:

- The paper must be loaded correctly and it must be taut and square.
- The paper may be sticking to the platen because the platen may be dirty. Inspect the platen and refer to the Cleaning the Platen section of Chapter 6 of this user's guide.
- The paper may be slipping because debris may have accumulated in the grit shaft, preventing the grit shaft from properly gripping the paper. Inspect the grit shaft and refer to the Cleaning the Grit Shaft section of Chapter 6 of this user's guide.
- You may have reached the maximum marker length of the Summit 910 (10 yards or 9.1 meters).
- Make sure the outermost chartwheels are at least six inches in from the edge of the paper.
- Inspect the paper for wrinkles or folds. Never use any paper that is folded, wrinkled, or torn in any way. Allow the paper to stabilize (temperature and humidity) at least one day prior to plotting.
- You may have to re-level the Summit 910.
- Check the frame gap setting.

Poor Line Quality

If your marker plot line quality is uneven or erratic, the Summit 910 pen force setting may be set incorrectly. Use the front panel force knob to set the pen force to a setting that produces adequate line quality.

- Inspect the pen to determine whether it is empty or running out of ink. Replace the pen if it is defective or empty.
- Reduce the speed and/or acceleration settings to improve the line quality.
- Check the pen force setting.
- Make sure you are using the correct pen type.
- Reload the paper.
- Make sure the pen is not clamped too high in the pen jaw.

THE FCC WANTS YOU TO KNOW...

This equipment generates and uses radio frequency energy and, if not installed and used properly (in strict accordance with the manufacturer's instructions), it may cause interference to radio and television reception. Operation is subject to the following two conditions: (1) This device may not cause harmful interference, and (2) this device must accept any interference received, including interference that may cause undesired operation. If this equipment does cause interference to radio or television reception - which can be determined by turning the equipment off and on - you are encouraged to try to correct the problem by one or more of the following measures:

- Use only shielded interface cables.
- Reorient the receiving antenna.
- Relocate the host computer with respect to the receiver.
- Move the host computer away from the receiver.
- Plug the host computer into a different outlet so that the host computer and receiver are on different branch circuits.

If necessary, consult your dealer or an experienced radio/television technician for additional suggestions. The following booklet, prepared by the Federal Communications Commission, is a helpful reference:

How To Identify and Resolve Radio-TV Interference Problems.
This booklet is available from the U.S. Government Printing Office, Washington, D.C. 20402. The stock number is 004-000-00345-4.

YOUR COMMENTS ARE REQUESTED

Ioline Corporation is interested in your comments on our documentation. Please send your corrections or suggestions to Ioline Corporation, 12020-113th Avenue N.E., Kirkland, WA USA 98034.

This User's Guide is provided for informational purposes only. The contents are subject to change without notice, and Ioline Corporation assumes no responsibility for any errors that may be contained herein. No part of this User's Guide may be copied, disseminated, or distributed without the express written consent of Ioline Corporation.

CUSTOMER SERVICE

Ioline Corporation is committed to providing quality service and support to our customers. If you need assistance with an Ioline product, contact your local dealer or Ioline authorized service center. You may also contact the Ioline Customer Service Department at: 1-206-821-2140 [7:00 a.m.-5:00 p.m. PST], FAX: 1-206-823-8898.

LIMIT OF LIABILITY STATEMENT

It is the responsibility of the operator of the Summit 910 Marker Plotter to monitor the performance of the Summit 910 Marker Plotter and maintain it in proper working condition by following the instructions in this User's Guide. It is the responsibility of the operator of the Summit 910 Marker Plotter to follow all safety precautions and warnings that are described in this User's Guide. Ioline is not responsible for injuries that may occur as a result of unsafe operating procedures. Ioline is not responsible for substandard operational performance as a result of failure to maintain the Summit 910 as described in this User's Guide.