

# IOLINE™



## Quick Start Guide

### I/S Series

I/S 60, 85, 110, 130



### SC Series

SC-40 & -48



# IOLINE SMARTRAC™

# USER NOTICE

## Trademarks

Ioline and SmarTrac are trademarks of Ioline Corporation. Other product names, logos, designs, titles, words or phrases mentioned within this publication may be trademarks, service marks, or trade names of Ioline Corporation or other entities and may be registered in certain jurisdictions including internationally.

## Ioline Disclaimer

IOLINE CORPORATION PROVIDES THIS MANUAL "AS IS" WITHOUT WARRANTY OF ANY KIND, EITHER EXPRESS OR IMPLIED, INCLUDING BUT NOT LIMITED TO THE IMPLIED WARRANTIES OR CONDITIONS OR MERCHANTABILITY OR FITNESS FOR A PARTICULAR PURPOSE. IN NO EVENT SHALL IOLINE, ITS DIRECTORS, OFFICERS, EMPLOYEES OR AGENTS BE LIABLE FOR ANY INDIRECT, SPECIAL, INCIDENTAL, OR CONSEQUENTIAL DAMAGES (INCLUDING DAMAGES FOR LOSS OF PROFITS, LOSS OF BUSINESS, LOSS OF USE OR DATA, INTERRUPTION OF BUSINESS AND THE LIKE), EVEN IF IOLINE HAS BEEN ADVISED OF THE POSSIBILITY OF SUCH DAMAGES ARISING FROM ANY DEFECT OR ERROR IN THIS MANUAL OR PRODUCT.

## Limit of Liability Statement

It is the responsibility of the operator of the signcutter to monitor the performance of the signcutter and maintain it in proper working condition by following the instructions in this User Guide. It is the responsibility of the operator of the signcutter to follow all safety precautions and warnings that are described in this User Guide. Ioline is not responsible for injuries that may occur as a result of unsafe operating procedures. Ioline is not responsible for substandard operational performance as a result of failure to maintain the signcutter as described in this User Guide.

© 1997-2005 Ioline Corporation. All rights reserved. This manual may not be copied, photocopied, reproduced, translated, transmitted or converted to any electronic or machine-readable form in whole or in part without prior written approval of Ioline Corporation.

## Service and Support

If you require assistance with an Ioline product, your local Ioline dealer or authorized service center is ready to help. Support information is also available 24/7 on the Ioline Web site—or you may contact Ioline directly:

**Ioline Corporation**  
**14140 NE 200th Street**  
**Woodinville, Washington 98072 U.S.A.**

Ioline Customer Service Department  
Monday through Friday  
7:00 A.M. - 5:00 P.M. U.S. Pacific Time  
**Voice: 1.425.398.8282**  
**Fax: 1.425.398.8383**  
**techsupport@ioline.com**  
**www.ioline.com**



# IOLINE SMARTRAC™

## Quick Start Guide

### **I/S Series**

I/S 60, 85, 110, 130

### **SC Series**

SC-40 & -48

# IMAGES & ILLUSTRATIONS

<b>Figure 1.</b>	The Ioline SmarTrac I/S Cutter Front View .....	viii
<b>Figure 2.</b>	The Ioline SmarTrac Contour (SC) Cutter Front View .....	ix
<b>Figure 3.</b>	Power and communications ports .....	x
<b>Figure 4.</b>	Proper lifting procedure. requires two people .....	11
<b>Figure 5.</b>	Attach the feet .....	11
<b>Figure 6.</b>	Connect the cross-member .....	12
<b>Figure 7.</b>	Insert the media rollers .....	12
<b>Figure 8.</b>	Place cutter on stand .....	12
<b>Figure 9.</b>	Place cutter on cradle .....	13
<b>Figure 10.</b>	Insert Screws in legs or cradle feet .....	13
<b>Figure 11.</b>	Remove packing foam and plastic strip .....	13
<b>Figure 12.</b>	Power cable and communication ports .....	14
<b>Figure 13.</b>	Computer communication ports .....	14
<b>Figure 14.</b>	The Ioline <b>Control Center</b> .....	14
<b>Figure 15.</b>	Vinyl loaded on media roller .....	15
<b>Figure 16.</b>	Place pinchwheels under drive shaft markers .....	15
<b>Figure 17.</b>	Align the vinyl .....	15
<b>Figure 18.</b>	Leave slack in the vinyl .....	16
<b>Figure 19.</b>	Inserting the blade (left) and the blade holder (right) .....	16
<b>Figure 20.</b>	Adjusting the blade exposure .....	16

# TABLE OF CONTENTS

TABLE OF CONTENTS

SAFETY & CAUTIONS

VISUAL REFERENCE GUIDE

<b>CHAPTER 1</b>	<b>Getting Started</b>	
	Step 1: Unpack .....	11
	Step 2: Assemble the Stand .....	11
	Attach the Feet .....	11
	Connect the Cross-member and Legs .....	12
	Insert the Media Rollers .....	12
	Step 3: Attach the Stand or Cradle .....	12
	Place Cutter on the Stand .....	12
	Place Cutter on the Cradle .....	13
	Finish Assembly .....	13
	Step 4: Finish Installation .....	14
	Connect the Machine Cables .....	14
	Install the Software .....	14
	Install USB Drivers .....	14
	Step 5: Prepare to Cut .....	15
	Position the Pinchwheels Over the Drive Shaft .....	15
	Square the Vinyl .....	15
	Position the Vinyl .....	16
	Insert a Blade, Load the Holder in the Jaw .....	16
	Adjust the Blade Exposure and Force .....	16



# SAFETY & CAUTIONS

Please read these safety guidelines before beginning operation of the signcutter. The signcutter uses a very sharp blade when cutting. The parts can move quickly. Always observe the following safety precautions:

- Do not allow the material to become suddenly taut between the cutter and a roll of material during plotting. A service loop of unrolled material is required for problem-free operation. Using the **Autoloop** function (enabled in the **Control Center**) will create the required service loop by gently pulling a set amount of material from the roll before cutting. Ioline recommends using the **Autoloop** function when plotting on a roll of material.
- Do not try to repair the machine without factory authorization. Only qualified service personnel should attempt any disassembly or access to internal components. If external mechanical adjustments are necessary, turn off the signcutter and disconnect it from all power sources (both the computer and the wall outlet).
- Be careful with hair, jewelry, or loose clothing near the signcutter. They can become caught in the mechanical parts.
- Never move the carriage by hand. Use the **Arrow** keys and let the machine do it.
- Keep hands away from the carriage when the signcutter is in operation. The carriage will automatically move to its right end position when the power is turned on.
- Be careful when lifting the signcutter. Hold the bottom surfaces of the signcutter to lift or move it.
- Keep fingers away from the drive shaft when the signcutter is in operation.
- Use caution when changing a blade in the blade holder. *See the Routine Maintenance chapter of the SmarTrac User Guide for the recommended procedure.*
- Be careful when handling the blades. They are sharp and could cause an injury if mishandled. Although the blades are made of an extremely hard material, they are brittle and can break if dropped or mishandled.

KEY	
<b>A.</b> Dust Cover	<b>E.</b> Idler Wheel
<b>B.</b> Drive Shaft Marker	<b>F.</b> Drive Shaft
<b>C.</b> Carriage	<b>G.</b> Pinchwheel
<b>D.</b> Blade Holder	<b>H.</b> Pinchwheel Lever

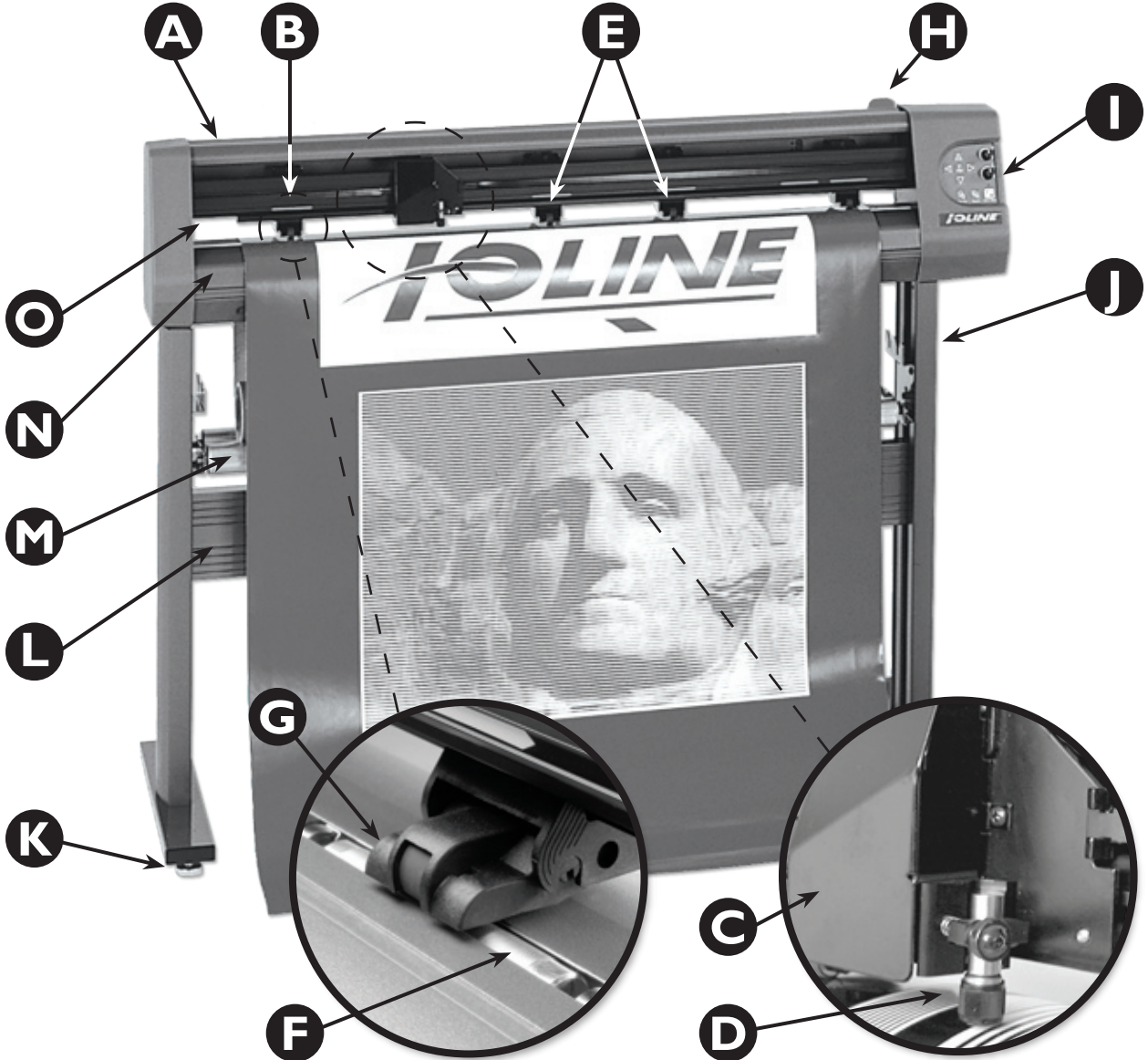

Figure I. The Ioline SmarTrac I/S Cutter Front View.

# VISUAL REFERENCE GUIDE

## KEY

- |                        |                 |
|------------------------|-----------------|
| I. Keypad              | M. Media Roller |
| J. Stand Leg           | N. Platen       |
| K. Stand Leveling Foot | O. Traverse     |
| L. Cross-member        | P. LED Sensor   |

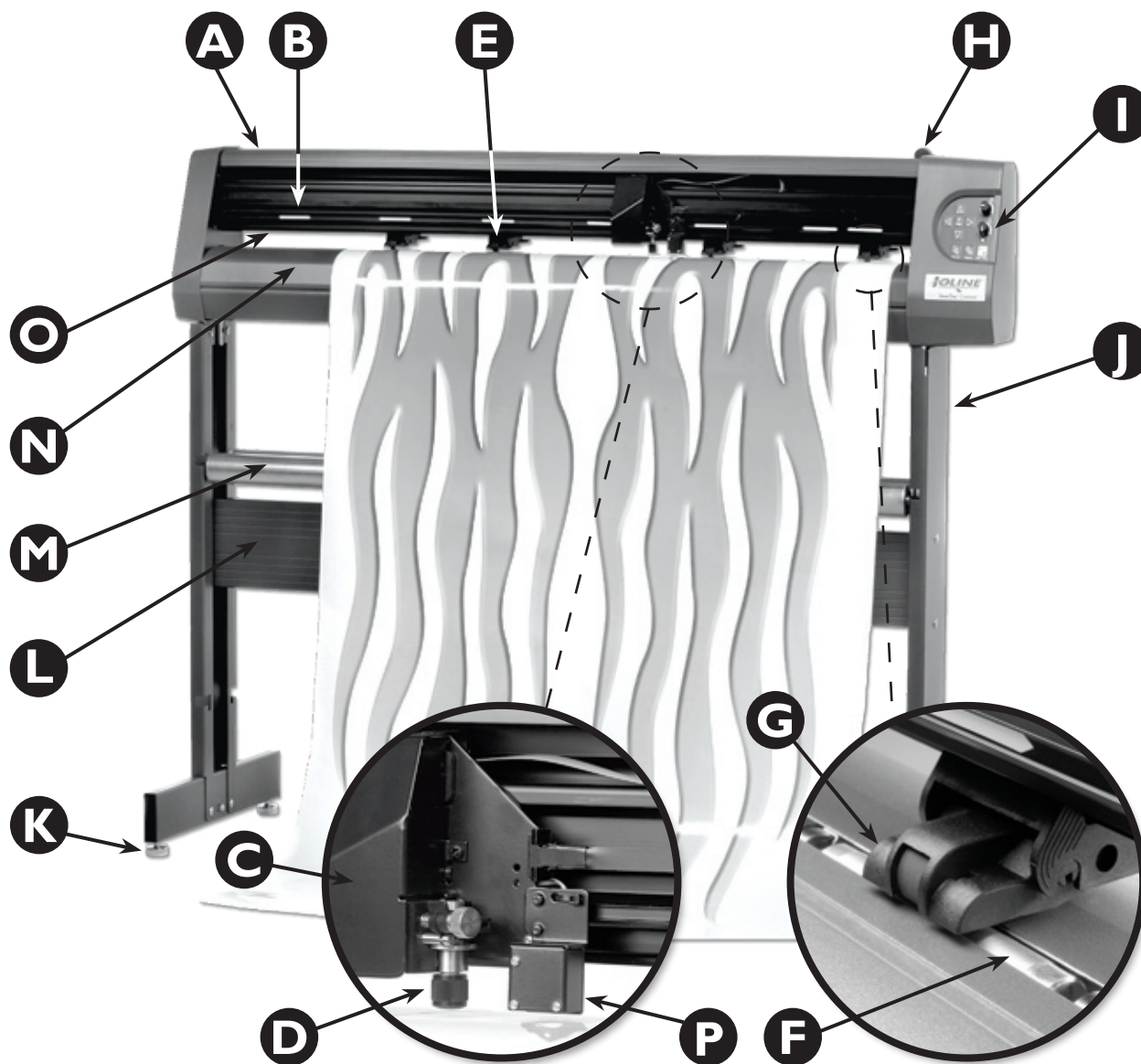
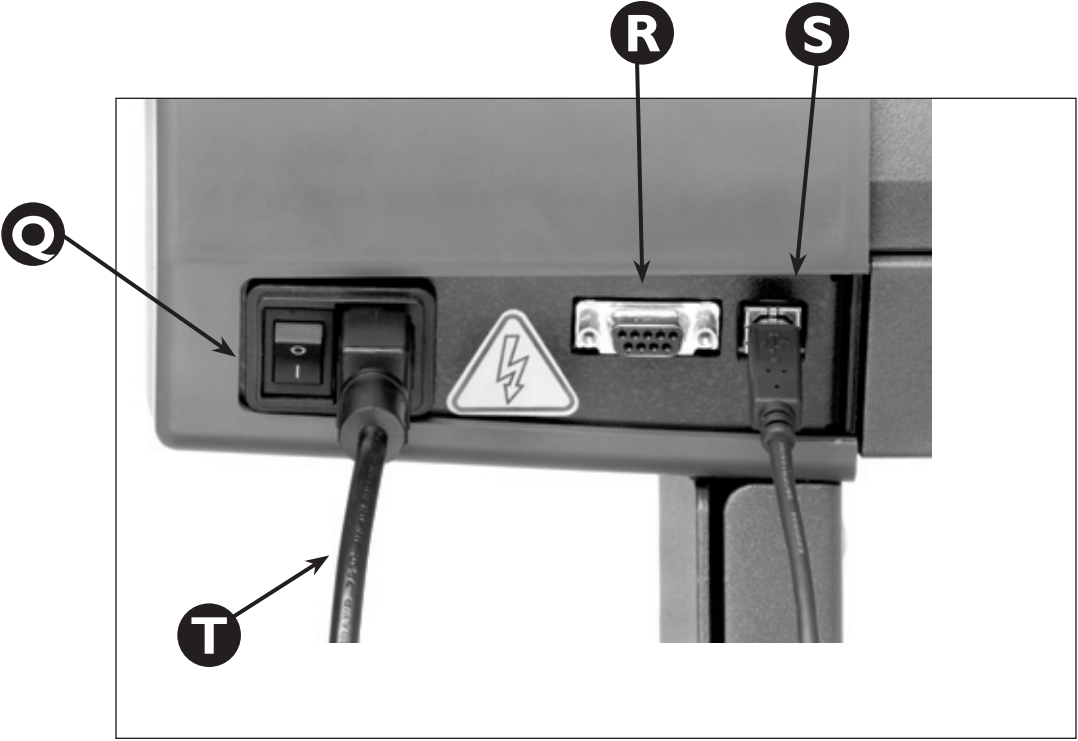

Figure 2. The Ioline SmarTrac Contour (SC) Cutter Front View.

KEY	
<b>Q.</b> Power Switch	<b>S.</b> USB Port
<b>R.</b> Serial (COM) Port	<b>T.</b> Power Cord



**Figure 3.** Power and communications ports on the Ioline SmarTrac I/S and SC models are located on the back of the right cover.

This *Quick Start Guide* shows how to assemble and setup the Ioline I/S, SC-40 and SC-48 model signcutters. Consult the *SmarTrac User Guide* on the CD-ROM for more detailed information about installation and operation. The *User Guide* may be printed from the provided Adobe® Acrobat® viewer if necessary.

## Step 1: Unpack

Remove the cutter, stand parts, and **Accessory Kit** from the box. Check the **Packing List**. Always use two people when lifting the signcutter, one person at each end. Save all of the packing materials.

### Required tools

- Phillips screw driver
- $\frac{7}{16}$ -in wrench

## Step 2: Assemble the Stand

(Optional for I/S 60 model)

### Attach the Feet

Attach one foot to each leg using three 1.5-in (long) Phillips screws and three  $\frac{7}{16}$ -in hex nuts. Repeat this procedure for the other leg. Screw all of the leg levelers halfway into the ends of the stand feet. Thread all four levelers in equally to ensure your signcutter is level and stable.

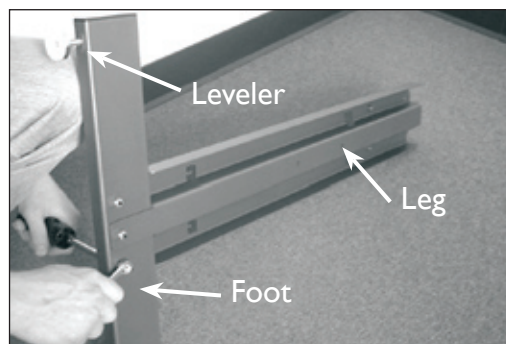
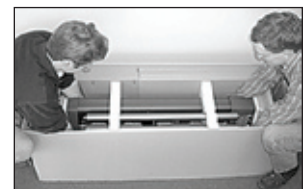

**Figure 5.** Attach the feet.

### CAUTION



Caution: The SmarTrac is heavy and could cause injury if it falls. A minimum of two people are required to safely unpack the plotter and attach it to the stand or cradle. One person should hold the machine while the second person screws it to the legs.



**Figure 4.** Proper lifting procedure. requires two people.

### Connect the Cross-member and Legs

The crossmember is reversible and can be attached upside down or from either side. Fit the crossmember snugly into the rectangular groove in one leg. Align the holes in the leg with the threaded holes in the crossmember. Insert two 1-in (medium) Phillips screws into the threaded holes. Leave them loose. Repeat this procedure for the other leg. Tighten all four screws.

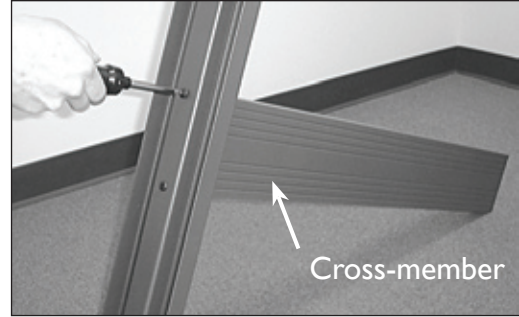

**Figure 6.** Connect the cross-member.

### Insert the Media Rollers

Insert the front media roller pins into the notches in the front of each leg. There are extra notches to accommodate different size rolls of media. Find the matching notches on the opposite leg to keep the roller straight. Repeat for rear media roller.

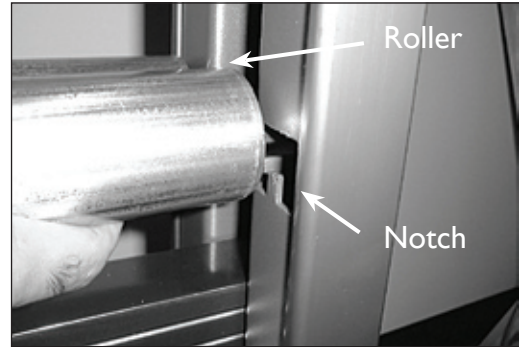

**Figure 7.** Insert the media rollers.

## Step 3: Attach the Stand or Cradle

### Place Cutter on the Stand

(I/S 85, 110 and 130 & SC-40, and -48 models)

One person should hold the cutter while the other person positions it. Slide the tabs on the bottom of the cutter inside the top of both legs. Make sure that the holes in the legs line up with the threaded holes in the tabs.



**Figure 8.** Place cutter on stand.

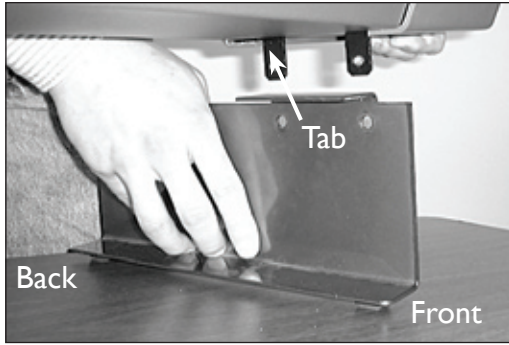

**Figure 9.** Place cutter on cradle.

the back of the machine. Make sure that the holes line up. The media support shaft fits in notches at the back of the cradle leg.

## Place Cutter on the Cradle

(optional on I/S 60)

Have one person hold the cutter while the other person positions the signcutter. Slide bottom tabs of the cutter outside the top of both cradle feet. The longer portion of the foot should extend from

## Insert the Screws

Have one person hold the cutter while the other person inserts the screws to secure the signcutter to the legs or cradle feet. Insert the  $\frac{3}{8}$ -in (short) Phillips head screws through the leg or cradle foot and into tabs on the cutter; Tighten.



**Figure 10.** Insert Screws in legs or cradle feet.

## Finish Assembly

Cut the plastic strap that holds the carriage in place during shipment and discard it. Remove and discard all packing foam from around the carriage to complete the assembly.



**Figure 11.** Remove packing foam and plastic strip.

**Note**

A serial cable is provided in the Accessory Kit.

**Note**

An adapter (not included) is required for 25-pin serial connections.

**Note**

The Setup program also allows installation of the electronic SmarTrac User Guides and the necessary viewer.

## Step 4: Finish Installation

### Connect the Machine Cables

Make sure power is off to the cutter (the switch is placed in the 0 position). Connect the serial or USB cable and the power cord to the panel on the back of the right side of the cutter. Plug the machine power cable into a wall socket or surge protector.

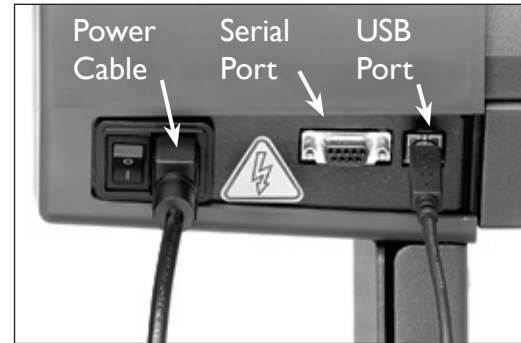

Figure 12. Power cable and communication ports.

### Connect the Computer Cable

With power to the computer off, connect the serial or USB cable to one of the ports on the back of the computer. See the *Installation* chapter of the *SmarTrac User Guide* for more information.

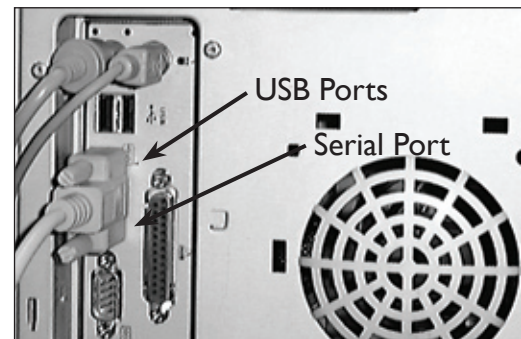

Figure 13. Computer communication ports.

### Install the Software

Insert the installation CD-ROM into the computer CD-ROM drive. The install program should start automatically. If it does not, select **Run** from the **Start Menu**. Browse to the CD-ROM and double-click on *Install Ioline Control Center* from the list of options. Press **OK** to start the install. Install the **Control Center** software.

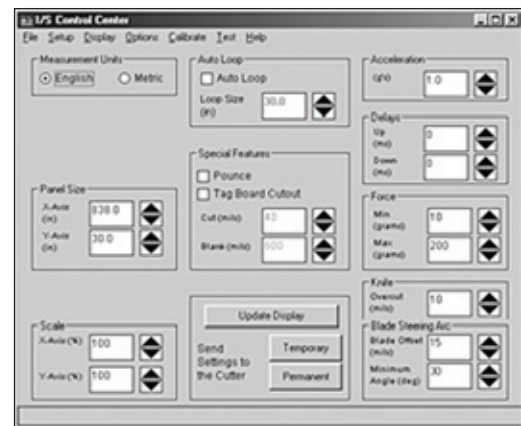

Figure 14. The Ioline Control Center.

### Install USB Drivers

Please see the guide labeled *Installing USB Drivers for Ioline Products* on the CD-ROM for the driver installation process.

## Step 5: Prepare to Cut



**Figure 15.** Vinyl loaded on media roller.

### Load the Vinyl Roll

Place a roll of vinyl onto the media rollers. With the pinchwheels up, thread the vinyl through the machine.

### Position the Pinchwheels Over the Drive Shaft

Move the vinyl and pinchwheels from side to side to find a position where the outermost drive wheels are on the vinyl about 1 inch from each edge, and over a drive shaft segment. Use the drive shaft markers (**Figure 16**) to determine where to place the wheels. The long drive shaft segment

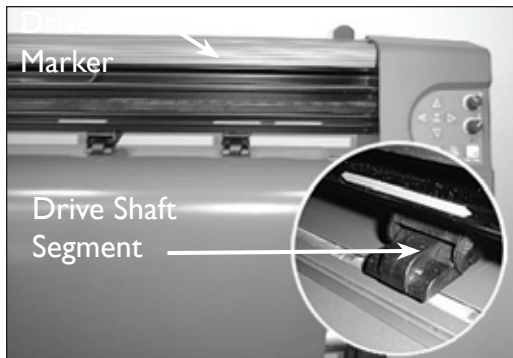

**Figure 16.** Place pinchwheels under drive shaft markers.

on the right side of the machine allows many pinchwheel positions for a variety of vinyl widths. Evenly space the inner idler wheel(s) (I/S 85, 110 and 130 & SC-40 and -48 models) over drive shaft segments. Make sure there is a minimum of one inch between the edge of the roll and the stand leg.

### Square the Vinyl

Lift the pinchwheels off the drive shaft using the pinchwheel lever. Pull enough vinyl through the machine so that it reaches the roll.



**Figure 17.** Align the vinyl.

Align the edge of the vinyl with the edge of the roll, making sure the vinyl is flat and square in the machine. Ensure that the outer pinchwheels are at least one inch from the edge of the vinyl. Lower the pinchwheels.

## Position the Vinyl

Do not let the vinyl become suddenly tight between the cutter and the vinyl roll. Manually unroll a few feet of vinyl from the roll to create a slack loop behind the machine.

Use the **Arrow** keys on the keypad to move vinyl through the cutter to check alignment. Adjust the vinyl if necessary so that it feeds straight. Position the vinyl edge two inches in front of the blade; Place the carriage an inch from the right edge.



**Figure 18.** Leave slack in the vinyl.



### Note

Be very careful when handling the blades as they are sharp and brittle and the tips can chip or break. Using a hard surface to insert the blade may damage it.

## Insert a Blade, Load the Holder in the Jaw

Unscrew the foot from the blade holder. Insert a blade into the hole in the blade holder, making sure it is fully seated. Replace the foot and adjust it so that the blade tip is barely inside the foot

with no blade exposed. Loosen the thumb screw on the carriage jaw and insert the blade holder. The flange slides into the slot in the jaw. Rotate the clamp down onto the flange and tighten the thumb screw until the blade holder is held securely in place.

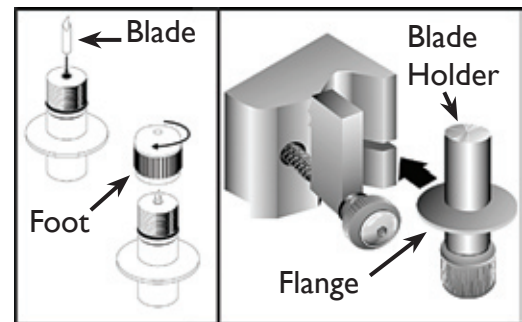

**Figure 19.** Inserting the blade (left) and the blade holder (right).

## Adjust the Blade Exposure and Force

Turn the **Force** knob on the keypad clockwise to maximum. Press the **Test Cut** key. There should be little or no scoring of the vinyl. Turn the foot 1/8-turn clockwise (from the bottom). Press the **Test Cut** key. Weed the test cut pattern and examine cut quality. Continue adding blade exposure

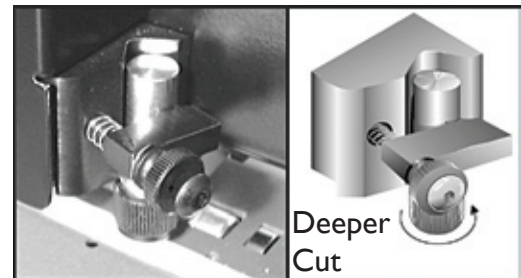

**Figure 20.** Adjusting the blade exposure.

and pressing **Test Cut** until the pattern weeds easily and the blade leaves a clear scoring on the backing.

To extend blade life, only set as much **Force** and blade exposure as is absolutely required to get a clean cut and good weed. Reduce the **Force** in small increments and perform more test cuts until the test cut pattern sticks slightly while weeding; Then, set the **Force** to the previous position. Press and hold the **Test Cut** key for 3 seconds. The cutter will cut a large test pattern as a final check. Move the carriage and vinyl to a starting position for the first file. Press the **Set Origin** key on the keypad. The light on the keypad will turn green.

The cutter is ready to cut. Refer to the ***SmarTrac User Guide*** and your design software documentation for more information about optimizing cutter performance.

**This page intentionally left blank.**

# INDEX

## A

Accessory Kit 11, 14  
Arrow keys vii, 16  
Autoloop vii

## B

Blade 16, 17  
Blade exposure 16  
Blade holder viii, 16

## C

CAD software. *See* Design software  
Carriage viii, ix  
Carriage motion  
Carriage rail ix  
CD-ROM 11, 14  
Communication  
    25-pin serial connection 12  
    Serial x  
    USB v, x  
Computer  
    Connection 14  
Control Center x, vii, 14  
Cradle 12, 13. *See also* Stand  
Cradle foot 13  
Cross-member v, ix, 12  
Cutting 15

## D

Design software 17  
Drive shaft v, viii

Drive shaft marker viii, 15  
Drive shaft segment 15  
Dust Cover viii

## E

## F

Flange 16  
Force 16, 17

## G

Getting Started 11–18

## H

## I

Idler wheel viii, 15  
Installation 14

## J

Jaw 16

## K

Keypad ix

## L

LED sensor ix

**Legs** 12

## M

### Media

- Loading 15
- Positioning 16
- Size 12
- Vinyl 15, 16

**Media roller** ix, 12, 15

**Media roller pin** 12

## N

## O

## P

**Packing List** 11

**Paper motion.** *See* **Plot**

### PC

- Connection 14

**Pinchwheel** viii, 15

**Pinchwheel lever** viii

**Platen** ix

**Power cord** x, 14

**Power switch** x

## Q

## R

## S

**Safety** viii, vii, 11

- Lifting procedure 11

**Serial port** x, 12, 14

- 25-pin serial connection 12

**SmarTrac User Guide** 11, 14, 17

**Software** 17. *See also* **Control Center**

### Stand

- Assembly 11–12
- Attaching to cutter 12
- Cross-member v, ix

- Legs 12
- leveling foot ix
- Media roller ix
- Notch for media roller pin 12
- Stand leg ix

**Stand leveling foot** ix

**Start point.** *See* **Origin**

## T

**Test Cut** 16, 17

**Tools** 11

## U

**USB** x

**USB port** 14

## V

**Vinyl** 15, 16. *See also* **Media**  
Loading 15

## W

## X

## Y

## Z