

ArtProTM Signmaker

GUIDE TO OPERATIONS

For ArtPro3500

ArtPro4000

TABLE of CONTENTS

1 Introduction

What is the ArtPro Signmaker?	1-1
How to Use This Manual	1-2
Section Descriptions	1-2
Conventions Used in This Manual	1-3
Notes	1-3
User Input	1-3
Computer Keys	1-3
On-Screen Material	1-3
Warnings	1-4
Cautions	1-4
Specifications	1-4

2 Installation and Setup

Installing the ArtPro Cutter	2-1
Installing the Cutter Blade	2-3
Mechanical Setup and Adjustments	2-7
Depth Adjustment Knob	2-7
Force Adjustment Knob	2-8
Final Adjustment	2-10
Hints on Material	2-12

3 Everyday Operation

Introduction	3-1
Your ArtPro3500	3-2
Making a Test Cut	3-2
Using Your ArtPro3500	3-2
Default Settings	3-3
Changing the Default Settings-ArtPro3500	3-4
Using your ArtPro4000	3-5
Making a Test Cut	3-5
Default Settings	3-5
Basic Operation of ArtPro4000	3-6
Changing the ArtPro4000 Offset Settings	3-7
Changing from Cut Mode to Pen Plotting Mode	3-7

4 Advanced Techniques

Setting Plotter Cutting Parameter	4-1
Offline Syntax Commands	4-5

5 Troubleshooting

Side Play in the Pen Holder	5-1
Cutter Bumps or Rubs on Dust Cover	5-2
Blades	5-3
Blade Skipping/Tearing the Vinyl	5-3
Care of Blades	5-3
Blade Cutting too Deep	5-3

1 INTRODUCTION

Section 1 is an introduction to Ioline's ArtPro Signmaker. This section will instruct you on how to use the ArtPro Signmaker Guide to Operation, and a description of the sections included.

WHAT IS THE ARTPRO SIGNMAKER?

The ArtPro Signmaker is a wide body production signmaker that employs a caster-style knife to cut signs easily and efficiently. With its convenience, accuracy and simplicity, your signmaker will become an indispensable part of your CAS program.

You can adjust the downward cutting force independently of the cutting depth. This allows you to fine tune the cutting performance of your new cutter for your application.

In addition, the cutter accommodates a range of blades with different front angles and offsets, so you can select the blade that works best for the material you're cutting.

The cutter also comes with advanced offset software to ensure the intricate details of your design are cut with precision.

We recommend that you read this operations guide thoroughly, so you can use your ArtPro Signmaker to its fullest potential for all of your vinyl sign cutting needs.

The ArtPro Signmaker functions also as a pen plotter. Please refer to your LP3500 or LP4000 Guide to Operations for further details

HOW TO USE THIS MANUAL

This manual is designed to help you correctly set up, operate, and maintain the ArtPro Signmaker.

SECTION DESCRIPTIONS

- Section 1, *Introduction*, provides an overview of the ArtPro Signmaker by describing its features and listing its specifications. Section 1 also contains a list of stylistic conventions that are used in this manual.
- Section 2, *Installation and Setup*, provides instructions for installation and adjustment of the ArtPro Signmaker, and hints on the material to use.
- Section 3, *Everyday Operation*, provides an overview of the ArtPro Signmaker.
- Section 4, *Advanced Techniques*, contains helpful instructions for the advanced user.
- Section 5, *Troubleshooting*, contains simple procedures to eliminate problems that may arise.
- *The Glossary*, is an explanation of technical terms used in this manual.

We are interested in your comments or suggestions regarding the contents of this manual, and have included a Request for Reader's Comment form at the end of the manual.

CONVENTIONS USED IN THIS MANUAL

Certain typeface conventions are used in this manual. These text designs will draw your attention to procedures, warnings, cautions, and other expressions. Following are illustrations of these conventions.

Notes

Note: Notes contain additional information or advice that may be helpful when you are running or configuring your ArtPro Signmaker.

User Input

Instructions for typing a computer command is as follows:

From the C> prompt is the root directory of your computer, type:

```
COPY A:FILENAME.EXT  
COM1:<ENTER>
```

Computer Keys

We have put angular brackets around computer keyboard keys. They will look like this:

```
<ENTER>  
<SHIFT>
```

On-Screen Material

We have represented text that appears on the computer screen like this:

```
ARTPRO
```

Warnings

> > **WARNING:** Warnings call your attention to safety procedures that must be followed in order to avoid potential personal injury.

Cautions

CAUTION: Cautions call your attention to procedures that must be followed in order to maximize equipment performance and avoid a loss of equipment effectiveness.

SPECIFICATIONS

Cutting Depth:	0.001-0.035 in. (0.025-8.89mm)
Cutting Speed:	1-8 i.p.s./20cm/s
Cutting Pressure:	50-150 grams
Blade Angle/Offset:	One 45°/0.015 in./0.38mm
Blade Material:	Tungsten Carbide
Dimensions:	1 1/2 x 1 1/2 x 3 3/8 in. 39 x 39 x 86mm
Weight:	0.4lb (0.18Kg)

2 INSTALLATION AND SETUP

In this section of the manual, you will learn how to install, make the necessary adjustments, and perform a test cut, using your ArtPro Signmaker.

INSTALLING THE ARTPRO™ CUTTER

Simply follow Steps 1 through 3 to attach the Cutter unit to your plotter.

1. Slide the Cutter Head into the Pen Holder. (See Figure 2-1). Tighten thumbscrews.

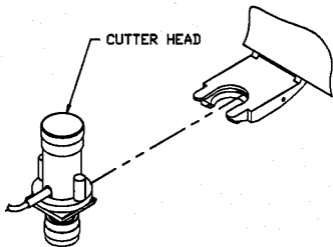

Figure 2-1 – Cutter Head and Pen Holder

2. Route the Cutter Cable through the groove in the Boom Block, through the self-adhesive cable clips, and insert the plug into the connector on the Right End Cover. (See Figure 2-2).

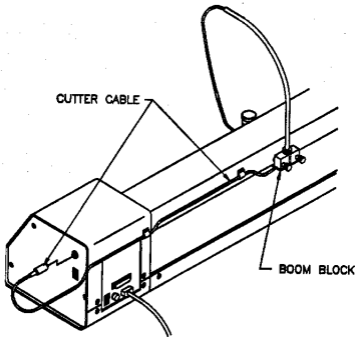

Figure 2-2— Routing Cutter Cable

3. Place the Cutter Switch on the Right End Cover in the CUT position.

INSTALLING THE CUTTER BLADE

Your ArtPro Signmaker is shipped with one .015 in./0.38mm offset blade. (See Figure 2-3).



**45° BLADE
15 MIL OFFSET**

Figure 2-3— Offset Blade

The offset refers to the distance from the point of rotation to the point of cut.

The .015 in./0.38mm offset blade is efficient whether your design is intricate with a lot of detail and/or lettering smaller than 3/4 inch/19mm, or designs having a combination of large and detail work.

The carbide blades used in the ArtPro Signmaker are very brittle, and can be easily broken. With normal use and care, they will last a long time. When not in use, protect them by putting the rubber covers over the tips and storing them in their protective cases.

Insert the blade as explained in the following steps.

1. Loosen thumbscrews and remove the **Cutter Head** from the **Pen Holder** and lay it upside down on the **Plotter Platen**. (See Figure 2-4).

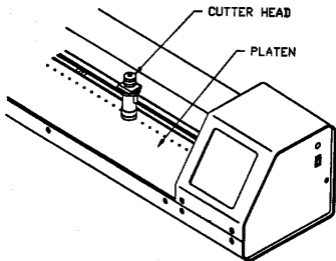

Figure 2-4— Removing Cutter Head From Pen Holder

2. Remove the Depth Adjustment Knob, (See Figure 2-5).

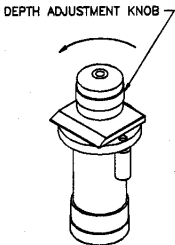

Figure 2-5— Removing Depth Adjustment Knob

3. Using a blunt instrument such as a toothpick, gently center the "O-ring" that is inside the blade cavity.
4. Carefully holding the blade tip between your fingers, start the blade insertion with a twisting motion, then firmly push the blade into the cutter using a plastic object such as the barrel of a pen, or felt-tip marker. You should feel the blade click into position. **DO NOT** use metal objects to seat the blade, as they may damage the sharp point. (See Figure 2-6).

Note: If the blade is difficult to insert, lightly grease the base with silicone grease, or other lubricant not harmful to rubber.

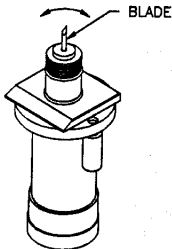

Figure 2-6— Inserting Blade

5. Re-attach the Depth Adjustment Knob, taking care not to set the depth such that any position of the blade is visible when the plunger is depressed.
6. Replace the Cutter Head into the Pen Holder and tighten knurled screws to secure.
7. To remove the blade, take off the Depth Adjustment Knob, and carefully pull out with finger tips.

> WARNING: The ArtPro precision-ground tungsten-carbide blade is extremely sharp. Use care when handling to avoid injury. Wrapping a piece of tape around the blade makes handling easier.

MECHANICAL SETUP AND ADJUSTMENTS

The Cutter has two major adjustment points, the **Force Adjustment Knob** and the **Depth Adjustment Knob**. (See Figure 2-7).

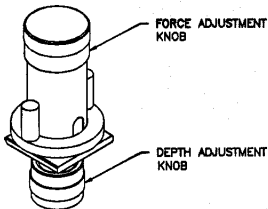

Figure 2-7 – Force/Depth Adjustment Knobs

Depth Adjustment Knob

The **Depth Adjustment Knob** controls the depth of the cut. This allows for variations in vinyl thickness.

When adjusted properly, the blade will cut through the vinyl and adhesive without cutting the backing material.

CAUTION: Do not allow the blade to protrude enough to cut into the metal platen.

Force Adjustment Knob

Because vinyl cuts more easily than the backing material, the **Force Adjustment Knob** can be used to fine tune the cutting by allowing the blade tip to cut through the vinyl, while riding on the top of the backing. This compensates for uneven thickness in some vinyl, and minute adjustment variances in the blade depth.

(See Figure 2-8).

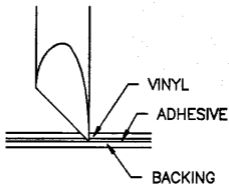

Figure 2-8— Blade Tip Riding on Top of Backing

When you begin using your cutter, you will probably rely on the **Depth Adjustment Knob** for controlling the depth of your cut. However, as you gain experience with your cutter, you may find the **Force Adjustment** feature gives you more control, particularly with uneven vinyl.

Note: To prevent the skiving effect of the blade lifting out of the vinyl, a greater force is required for precision cutting when cutting at high speed.

To set these adjustments:

1. Hold the **Cutter Head** in hand and press down on **Force Adjustment Knob**.
2. Adjust the **Depth Adjustment Knob** so that the tip of the **Cutter Blade** is just visible below the bottom edge of the knob. (See Figure 2-9). **DO NOT** attempt to adjust the final cutting depth by sight. This adjustment should only be done with test cuts described in **FINAL ADJUSTMENT** in this section.

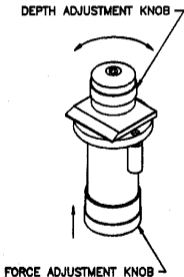

Figure 2-9 – Adjusting Blade Depth

3. For maximum force, tighten the **Force Adjustment Knob** until you encounter some resistance, then loosen it about 1 to 1 1/2 turns.

CAUTION: Extreme caution must be observed to make sure you do not over tighten the Force Adjustment Knob. When you encounter resistance, you are at the end of the adjustment range. If you continue to tighten the adjustment knob by applying more force, you can damage your cutter tool.

For less force, continue to loosen the Force Adjustment Knob as required.

4. Replace the Cutter Head in the Pen Holder.

FINAL ADJUSTMENT

1. Adjust the Cutter to the required depth using the following steps. (To perform plotter commands, refer to the enclosed LP3500 or LP4000 GUIDE TO OPERATION MANUAL).
2. Perform a test cut . This is done with an ArtPro3500 by sending the plotter the command ;:ITC from the computer. The ArtPro4000 will make a test plot when you press:

ALT 7 .

3. Blade depth should be adjusted so that vinyl can be weeded with little or no scoring to backing of vinyl. If blade cuts through backing, **DECREASE** blade depth by turning **Depth Adjustment Knob CLOCKWISE**, as viewed from top. If blade does not cut deep enough, and weeding is difficult, **INCREASE** depth of cut by turning **Depth Adjustment Knob COUNTER-CLOCKWISE**, as viewed from top. (Refer to Figure 2-9).

Note: As you change vinyl or blades, you may have to repeat this procedure to optimize performance.

4. Thicker and tougher types of signmaking material may require the use of the extra weight piece provided with the Cutter. To use the weight piece, slip it over the CUTTER BARREL and the two (2) knurled screws. Force adjustment may be required when using the weight piece. High performance and economy (3-4mil) vinyls usually do not require the added weight.

HINTS ON MATERIAL

The cutting of any material more than 10 mils (.010 in./0.25 mm) is difficult. However, with careful adjustment of the tool and very low speed, some materials up to 24 mils (0.024 in./0.61 mm) can be successfully cut.

The vinyl used must have a backing material which remains intact during cutting. The moving media plotter is not made to be used to cut parts completely out of the material. The cut parts, with missing sections, could become jammed in the plotter.

3 EVERYDAY OPERATION

Section 3 provides a detailed explanation and instructions on using your ArtPro Signmaker.

INTRODUCTION

The Ioline ArtPro Signmaker employs a trailing blade type cutter, that is, the tip of the blade follows along behind the axis of rotation, like a caster wheel. As your design is cut, there are many changes in direction which the cutter must follow. Because the blade follows behind the axis of rotation, the tip of the blade may not be in the correct position to begin a new cut each time there is a change in direction of movement. This causes the cutting of corners to be rounded. The Ioline built in offset is designed to solve this problem.

The ArtPro Signmaker has a built-in offset correction in the ROM. Therefore, a plot file can be sent directly to the plotter.. This makes using your ArtPro Signmaker a simple process of creating your plot file in your signmaking software program, then sending that plot directly to the cutter.

YOUR ARTPRO3500

MAKING A TEST CUT

Whenever the plotter is turned on, the ArtPro Offset correction is on. A test cut can be made by sending the plotter ;!TC@. This will cause the cutter to cut a small square to test the blade depth. Use this cut to adjust your knife blade setting, then make a second test cut to ensure the proper cutting depth before beginning a cut on your pattern.

USING YOUR ARTPRO3500

First you will want to create a directory labeled ARTPRO. To create this directory, and to copy the software to it, complete the following steps.

1. From the C:\> prompt of your computer type:

```
MD ARTPRO
```

Press <ENTER>

2. Insert the utilities diskette into the A drive. Close the drive door, and at the C:\> type:

```
CD\ARTPRO
```

Press <ENTER>

3. At the C:\ >ARTPRO > prompt type:

COPY A: *.*

Press <ENTER>

4. The files are now copied to your hard disk, and installation is complete.
5. Create your design using your CAS program.
6. You may send this file directly to the cutter without any changes to the plotter. If you wish to change the default settings you must do so before sending your design to the cutter.

DEFAULT SETTINGS

The ArtPro3500 default values are as follows:

The knife offset correction is on. To turn this offset correction off for pen plotting, turn the plotter power on while holding in the red front panel button until the LED flashes green once.

The knife offset correction distance is set at 15 mils (.015 inch).

The smallest direction change at which the plotter will perform a correction for the ArtPro knife is called the minimum correction angle. This minimum correction angle is set at 60 degrees.

The default pen speed is set at 4 inches per second.

CHANGING THE DEFAULT SETTINGS ON THE ARTPRO3500

The **HOSTART.EXE** program for PC-compatible computers can change these settings from the host computer.

Type **HOSTART** which brings up the hostart program.

Select the **KEYPAD** option from the menu by pressing the **<ENTER>** key on your keyboard.

Select either **ENGLISH** or **METRIC** units of measurement. Press **<ENTER>**.

Select the **KNIFE** option.

Once the knife option has been selected a menu with **ENABLE OFFSET**, **OFFSET DISTANCE**, and **MINIMUM ANGLE** will come up. Select the option(s) you wish to change by moving the highlighted bar to the option and pressing the **<ENTER>** key. Enter the new value you wish to use.

Exit out of the hostart program by pressing the **<ESC>** key then **<Q>** quit.

IMPORTANT: Each time the plotter is turned off, the settings you have just set will be lost and the plotter will revert back to the default settings.

USING YOUR ARTPRO4000

The ArtPro4000 has the offset correction built into the ROM much like the ArtPro3500. Therefore, a plot file can be sent directly to the plotter.

MAKING A TEST CUT

On the ArtPro4000 a test cut can be made by pressing the ALT 7 button on the plotter keypad. This will cause the cutter to cut a small square test pattern to test the blade depth. You can then adjust the blade and make a second test cut to ensure the proper cutting depth before beginning a cut on your pattern.

THE DEFAULT SETTINGS

Whenever the plotter is turned on the knife offset correction is enabled. If you wish to do pen plotting you must disable this setting.

The knife offset distance is set at 15 mils (.015 inch)

The minimum correction angle (the smallest direction change at which the plotter will perform a correction for the ArtPro knife) defaults to 45 degrees.

The default pen speed is set at 8 inches per second.

BASIC OPERATION OF ARTPRO4000

To cut using the default settings:

- 1. Put the cutter in the carriage.**
- 2. Set the Cut/Plot switch to Cut.**
- 3. Set the size limits of your vinyl**

Using the arrow keys, move the cutter to the lower left corner of the vinyl. Press:

LL

Move the cutter to the upper right corner of your vinyl. Press:

UR

- 4. Press :**

ON LINE

Your cutter is ready to receive Cut/Plot files from your host computer.

CHANGING THE ARTPRO4000 DEFAULT SETTINGS FROM THE PLOTTER KEYPAD

THE KNIFE OFFSET

To enable the knife offset and set the offset distance in mills, press these keys:

ALT 0 . n .

(n = offset in mills).

Example, if a 15 mil offset (.015 in) is needed press the keys:

ALT 0 . 15 .

CHANGING FRM CUT MODE TO PEN PLOTTING MODE

If you wish to use your signmaker for pen plotting, you must first disable the knife offset feature by changing the offset distance to 0. To do this press these keys:

ALT 0 . 0 .

THE PEN CHANGER OPTION

To enable the optional pen changer feature for multi-pen plotting press these keys:

ALT UR n

(n = 1, 2, OR 3) User areas 1, 2, or 3.

ALT 0 . 0

ALT PEN UP

4 ADVANCED TECHNIQUES

This section contains helpful instructions for the advanced user.

SETTING PLOTTER CUTTING PARAMETERS

On the Ioline ArtPro4000, it is possible to save a set of cutter settings (parameters) in each of three user areas or memory. These parameters can be entered from one of the three user areas on power up or reset, or selected by "entering" the user area during normal operations.

Several of the parameters that the user is able to change are very useful when cutting vinyl. The program KEYPAD.EXE on the LP3700/LP4000 diagnostic and utility diskette, shipped with each plotter, makes changing these parameters easy.

Below is a sample screen from this program, showing the changes that can be made in the user area of an ArtPro4000:

ENTER > Main Menu.

User number 1

- A > Pen changer is AUTOMATIC (1)**
 - B > Pen changes are Executed (0)**
 - C > Plotter language is HPGL (1)**
 - D > Automatic view on paper size set is OFF (0)**
 - E > HyperBUFFER is Mode 3 (Full optimize)**
 - F > Micro-calibration correction factors are X,Y:
1.000, 1.000**
 - G > Baud rate is 9600 (9)**
 - H > Pen mapping hst (pltr) 1-> (1) 2-> (2) 3->
4-> (4) 5-> (5) 6-> (6) 7-> (7) 8-> (8)**
 - I > Custom plot size #15 200.00mm. x
150.00mm.**
 - J > Custom plot size #16 1000.00mm. x
500.00mm.**
 - K > Pen up delay is 16ms.**
 - L > Pen down delay is 70ms.**
 - M > Keypad velocity is 10 i.p.s.**
- Enter line to change <A-M> :**

Some changes that can be made to improve cutting capability are explained as follows:

● **Set selection A > to (0) MANUAL**

This will disable the automatic pen changer. This is important because the pen changer feature can interfere with the cutter adjustments.

● **Set selection B > to "Ignored" (1)**

With the automatic pen changer function disabled, (see above), the plotter will stop and wait for you to change the pen when a pen change command is received. With a cutter installed the plotter needs to be told to ignore any pen change commands. By selecting (1), the "stop for pen exchange" function is disabled.

● **Set selection D > to OFF (0)**

This disables the automatic paper movement on setting a paper size.

● **Set selection E > to 0 or 1
(if plotter is equipped with a hyperBUFFER)**

The hyperBUFFER option for the ArtPro4000 performs different functions at each level of optimization. In modes 2 and 3, the plot information is optimized for minimum Y-axis movement. This makes a plot file execute faster if being drawn by a pen, but it will cause the software corrections for the ArtPro blade to be incorrectly executed. This can adversely affect the cutting quality and cause gaps in the cut. For this reason, Mode 0 or 1 should be entered.

In Mode 0 operation (ALT 00 on the plotter keypad), the hyperBUFFER performs none of its functions, only acting as a "wire" and passing data straight through. There would be no effect on the quality of the cutting output.

In Mode 1 operation (ALT 01 on the plotter keypad), the hyperBUFFER performs data compression, and acts as a linear buffer, first in, first out. There would be no effect on the quality of the cutting output.

● **Set selection M >
to a fairly low speed, (2 to 7 i.p.s.)**

The slower you move the blade, the better your output quality will be. It is recommended moving the blade 3 to 5 i.p.s.. If you are using high performance material, good results can be obtained using faster speeds (6 to 8 i.p.s.).

On the Main Menu of the keypad program, there is an option to set a "Power-up User" by number. Set the number of the user area you have saved these changes to as the "Power-up User", and these parameters will become the plotter defaults at power on.

IOLINE SYNTAX COMMANDS

The following Ioline syntax are used to change the knife variables.

- **KEn: Knife Enable**

n=0 (zero) disables offset correction for pen plotting.
n=1 (one) enables offset correction for the ArtPro cutting system.

- **KOn: Knife offset distance**

n = the offset distance in mils.

- **KAn: Knife Angle**

n = the number of degrees. This sets minimum angle that will force a correction. If the angle is set higher, the plotter will perform fewer corrections, causing an increase in speed and throughput and a loss in accuracy. If the angle is set lower, the accuracy is greater and the angles are sharper.

To execute changes to these functions from your device driver, build a function that sends the following commands to the plotter, or use a utility to send the commands from a system shell:

::! begins a command series

! ends a command series.

EXAMPLE: The blade being used in the ArtPro Signmaker has a 15 mil (.015 inch) offset, the offset correction in the plotter is to be enabled. You wish to set the minimum correction angle to 45 degrees so that the characters have sharp corners even at small direction changes. The following string, sent to the plotter as ASCII plot data will configure it:

::!KE1KO15KA45!

5 TROUBLESHOOTING

Section 5 contains simple procedures to help eliminate any problems that may arise when using your ArtPro Signmaker.

SIDE PLAY IN THE PEN HOLDER

Indications of side play are:

1. Letters are not being cut completely, beginning and ending of cut not matching, and leaving a gap in the cut.
2. The Cutter Assembly appears to "sway" or "tilt" slightly while changing directions during a cut.

There should be no side play in the Pen Holder. If there is, it can be corrected by tightening the cone point bearing screws. Using the allen wrench provided with your plotter, carefully tighten each screw equally. The point of each bearing screw should engage the mating hole in the carriage. When properly adjusted, the empty pen holder will fall when lightly tapped with your finger tip, and will nearly fall under its own weight. (See Figure 5-1).

CAUTION: Care must be taken not to over-tighten, as this may damage the pen carriage.

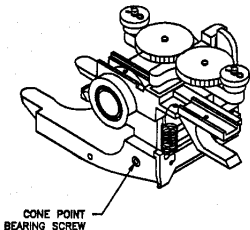

Figure 5-1 — Pen Holder

CUTTER BUMPS OR RUBS ON DUST COVER

If the cutter bumps against or rubs on the plotter dust cover, check to see that the cut/plot switch is set to **CUT**. (Figure 5-2). If the clearance is still too tight, loosen the dust cover screws and gently push the cover back while re-tightening the screws. If this does not solve the problem, call your service representative or Inline Customer Service.

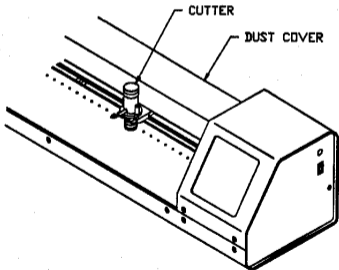

Figure 5-2— Cutter and Dust Cover

BLADES

Blade Skipping/Tearing the Vinyl

If the knife is skipping or tearing the vinyl, it could be caused by a dull or broken blade. A magnifying glass can be used for examining the blades for broken tips or edges. If it is damaged, remove the blade and replace with a new one.

Another thing that might cause a blade to skip is a small bit of vinyl or other foreign material sticking to the blade, preventing it from swivelling freely. Inspect the blade with a magnifying glass and carefully remove any foreign material.

Care of Blades

Protect your blades when not in use by storing them in their protective cases, with the rubber covers over the tips. The carbide blades used in the ArtPro Signmaker are very brittle, and can be easily broken. With normal use, they will last a long time.

Blade Cutting too Deep

If the cut is good when the vinyl is moving toward the front of the plotter (positive X axis direction), but is too deep when the vinyl is moving toward the rear of the plotter (negative X axis direction), add more downward force to the cutter "foot". This will provide more support against the blade digging into the vinyl.

To adjust the force:

1. Find the Pen Force Adjustment Arm under the Dust Cover on the rear of the Pen Holder Arm.
(See Figure 5-3).

2. Push the pen force adjustment up or down to decrease or increase the pen force. Each new downward position of the arm increases the pen force by approximately 10 grams; the range of adjustment is 20 to 60 grams.

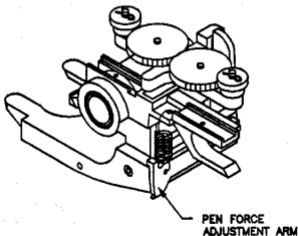

Figure 5-3— Adjustment Arm

GLOSSARY

CARRIAGE

The unit that holds the cutter or pen holder and travels along the traverse rod of the plotter.

COM PORT

The computer serial port. Usually numbered 1 or 2.

DM/PL

Digital Microprocessor/Plotting Language your design software uses to communicate with the plotter.

Refers to Houston Instruments DMP Plotter Driver.

HP-GL

Hewlett-Packard Graphics Language your design software uses to communicate with the plotter.

Refers to plotter driver being used.

MANUAL MOVE

Moving the vinyl or cutter through a series of keystrokes on the computer or plotter keypad, (as opposed to software driven moves).

MINIMUM CORRECTION ANGLE

The smallest direction change at which the plotter will perform a correction for the knife.

OFF-LINE

The keypad mode selection for moving the cutter and the media, and for selecting plotter settings. The indicator light next to the on-line key of the LP3700 is off, LP3500 is never off-line.

OFFSET

The distance (in mils) from the center of the cutter blade rotation to the tip of the blade.

ON-LINE

The keypad mode selection for sending a cut/plot file to the plotter. The indicator light next to the on-line key of the LP3700 is on, LP3500 is always on-line.

PARAMETER

A number, with variable values, that can be specified by the user.

PEN HOLDER

The unit that is attached to the carriage to allow the plotter to hold the cutter.

PLATEN

The surface of the plotter that the vinyl moves over during cutting.