

Procedure: Y fine adjustment for the Service Station.

Tools Required:

Scotch Tape

Service Station centering

1) Remove the right side cover of the machine.

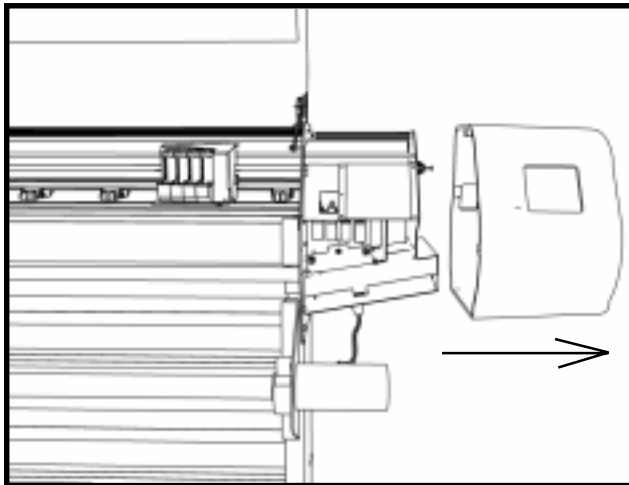

2) Remove the (four) screws that hold the keypad on. Let the keypad hang.

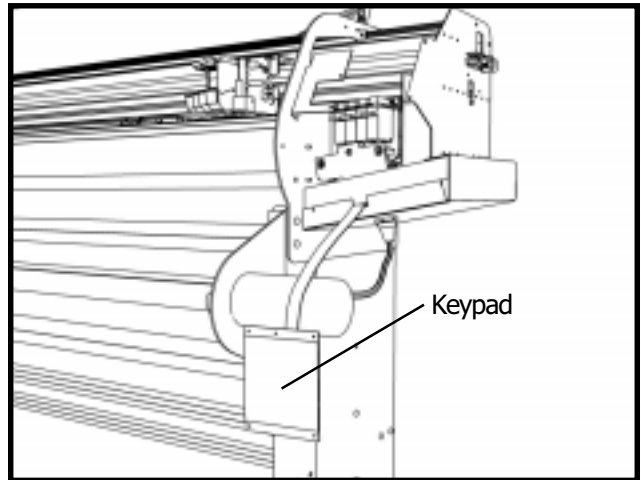

3) Remove the carriage cover. (One screw on the right side, un-clip the back right and left sides).

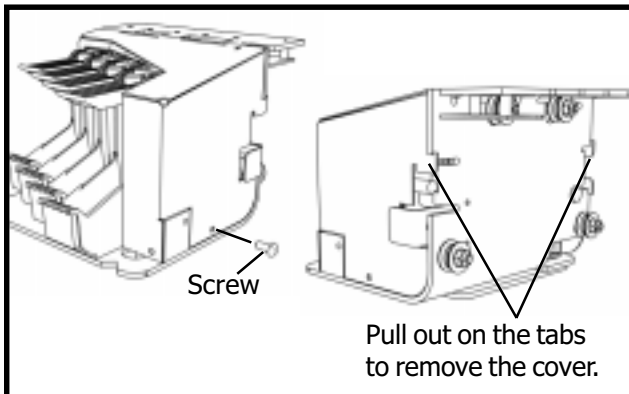

4) Make sure the ink cartridges are installed and power the machine on.

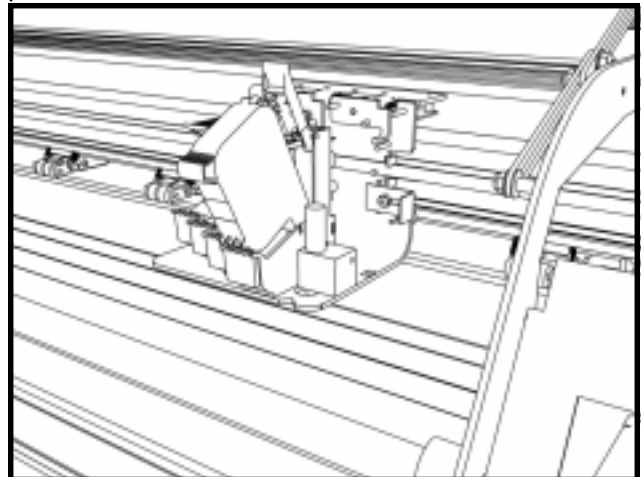

5) Loosen (do not remove) the carriage "stop bracket".

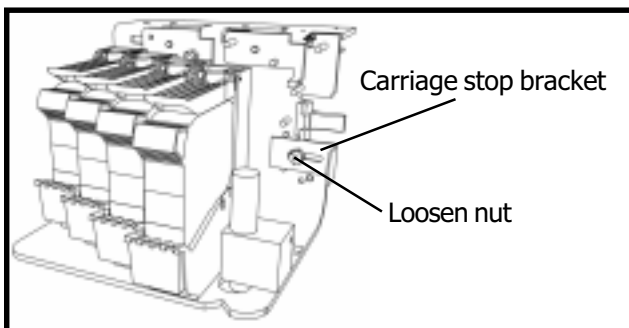

6) Place a piece of scotch tape on the service station spit wells.

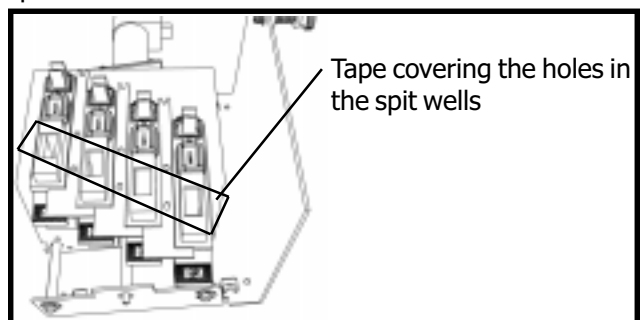

7) Press the "Clean" button on the keypad. You should see two lines in the middle of the spit well holes.

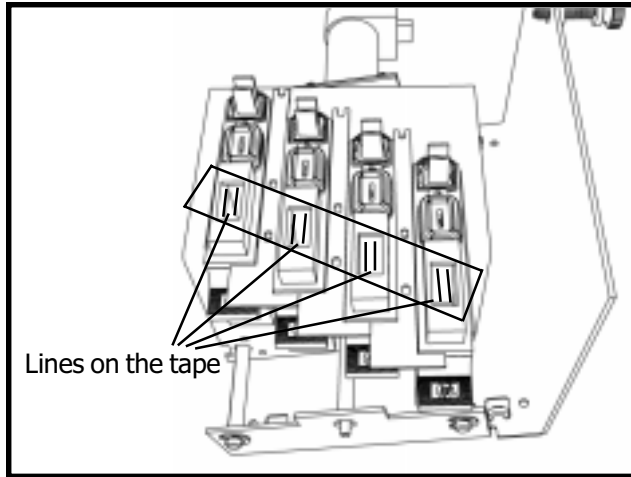

8) If the lines don't appear in the middle of the holes, turn the plastic thumbscrew on the side of the service station (clock-wise if the lines are to the right. Counter-Clockwise if the lines are to the left.)

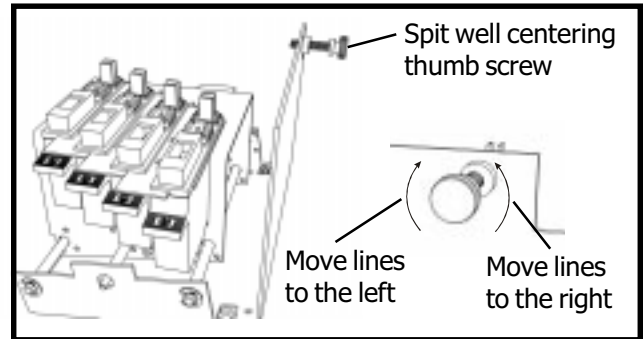

9) Turn the power off and remove the ink cartridges. **WARNING:** After removing the ink cartridges lower the blue ink doors before continuing.

Y Fine Adjustment

- 1) Turn on the FlexJet and let it initialize.
- 2) Open the "FlexJet Control Center" software.
- 3) When the window opens press Ctrl-Alt-B. You should see the following window.



- 4) Click the "Move carriage out from SS" button. The carriage will move out of the Service Station.
- 5) Change the "Y fine adjust" number to 20 and click the "Set fine adjust" button.
- 6) Click on the "Return carriage to SS" button. The carriage will move back into the Service Station.

7) Look at the gap between the bottom of the carriage and the service station. They should be touching just barely.

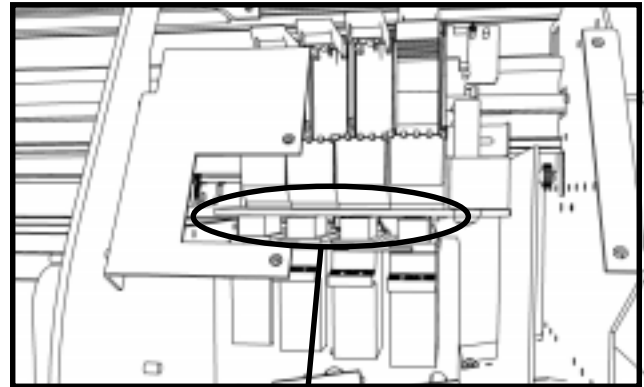

Look at the gap between the carriage and service station.

8) If there is still a gap between the carriage and the service station follow steps 4 thru 6 again adding 20 to the "Y fine adjust" number each time.

Perform these steps until there is no gap between the carriage and the service station.

- 9) Once the gap is set turn the machine off.
- 10) Press and hold the "UP" arrow on the keypad of the plotter. While holding the button turn the machine back on. When the carriage starts to move let go of the button.
- 11) Once the carriage is back in the service station check the gap one more time to make sure they are touching.

Final screw adjustment

1) If you are happy with the spacing between the carriage and the service station turn the service station stop screw on the side of the machine until it just touches the service station.

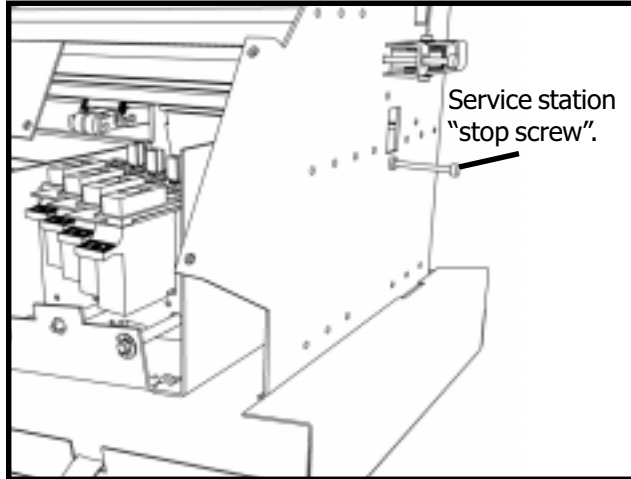

2) Back the screw off one half turn until you can see a little bit of light between the screw and the service station. Apply Lock-Tite or Super-Glue to the screw so it won't back out while the machine is running.

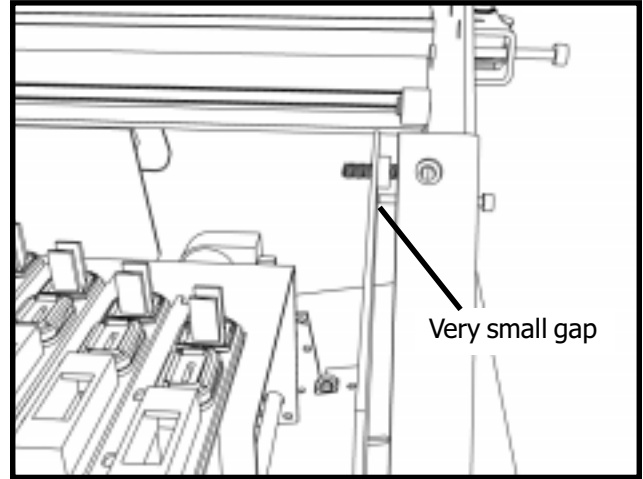

3) Move the carriage stop bracket until it hits the magnet. Tighten the nut to hold the stop bracket. Note: It's best to use a nut driver that can reach the nut while the carriage is in the service station. Otherwise tighten the nut enough to hold the bracket and move the carriage out of the service station to tighten the nut.

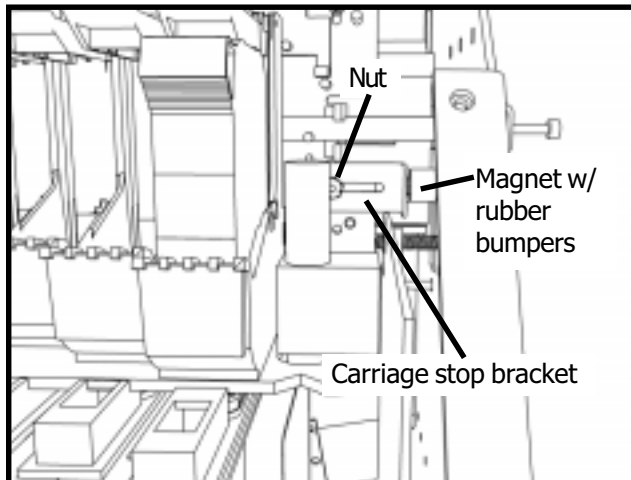

- 4) If you are happy with all the adjustments, turn the power off on the machine.
- 5) Let the FlexJet sit for 10 seconds, then turn the power back on while holding the "Up" arrow on the keypad. When the carriage starts to move let go of the button.
- 6) When the carriage initializes into the service station check all the gaps and stop brackets to make sure the adjustments are still right.
- 7) Re-install the keypad.
- 8) If problems arise contact Ioline Tech Support.