

MANUAL ADDENDUM

Plotter Models 600A and 28A



The 600A and 28A apparel plotters are very similar to the 600 and 28 plotters. There are a few notable exceptions:

NEW SETUP PROCEDURES

- **Single Crossmember** - The 600A/28A stand uses a single crossmember positioned for greater stiffness. Secure the crossmember to the stand legs with four 1 inch long screws.

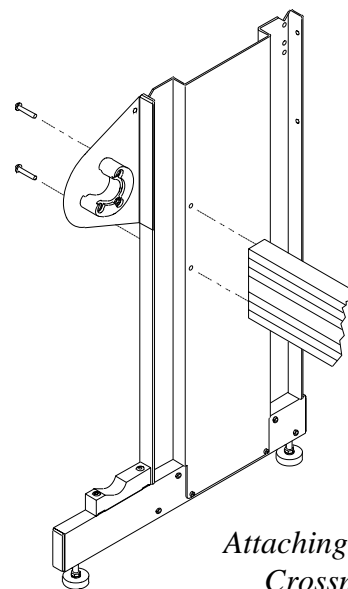

Attaching the Single Crossmember

PAPER LOADING DIFFERENCES

- **No Brake** - Paper feeding with the new drive shaft does not require a feed roll brake. Make sure that the flanged end of the feed shaft is cradled in the left or right support blocks.

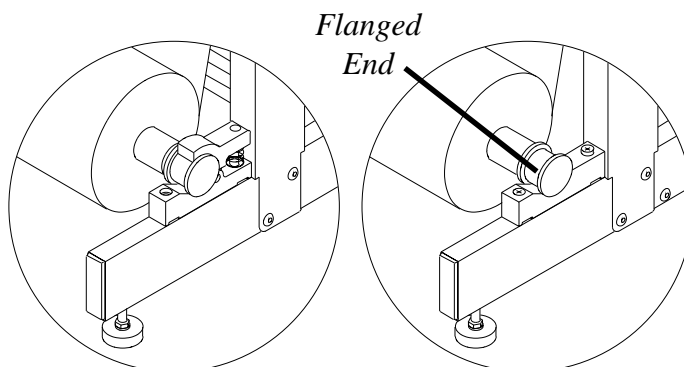

Old Feed Roll Block

New Feed Roll Block

- **28A Take-Up Tube** - Plotter model 28A uses a narrow take-up roll that is similar to the feed roll.

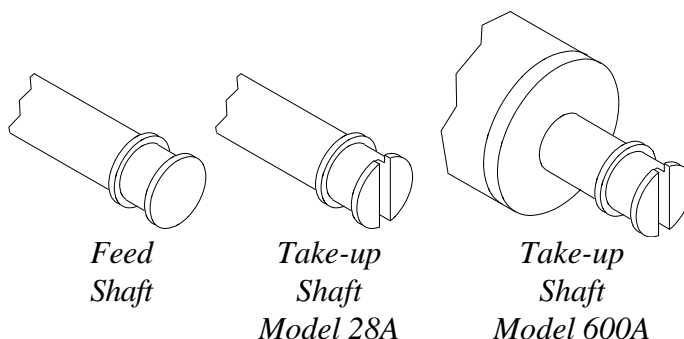

Feed Shaft

Take-up Shaft Model 28A

Take-up Shaft Model 600A

- **Drive Shaft** - The new drive shaft system is capable of accurately tracking most materials at greater speeds and accelerations. Gray markers on the traverse show the location of the drive shaft segments. Use these markers to position the pinchwheels over drive shaft segments when they are covered by paper.

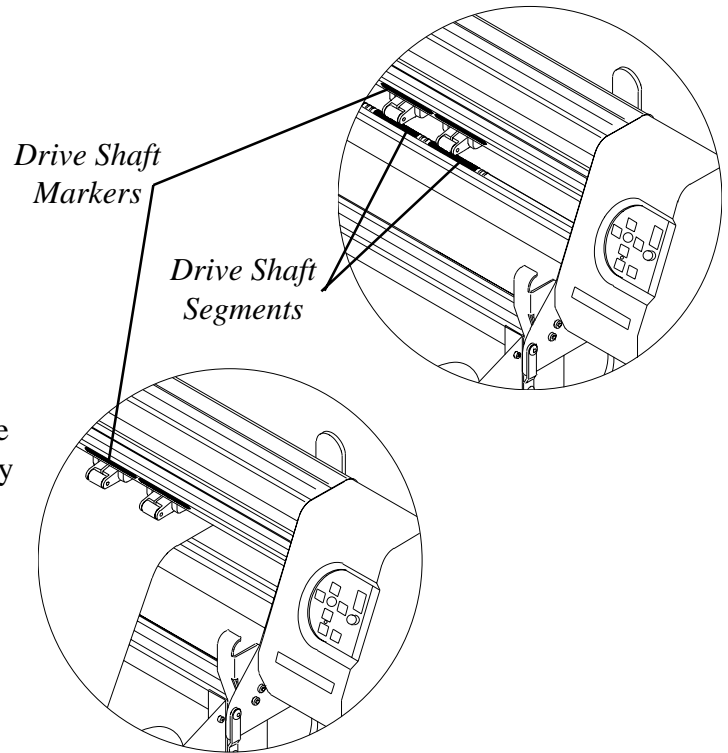

- **Pinchwheel Lever** - The pinchwheel lever is behind the dustcover on the right side of the machine, not in front. Push the lever away from the plotter to raise the wheels.

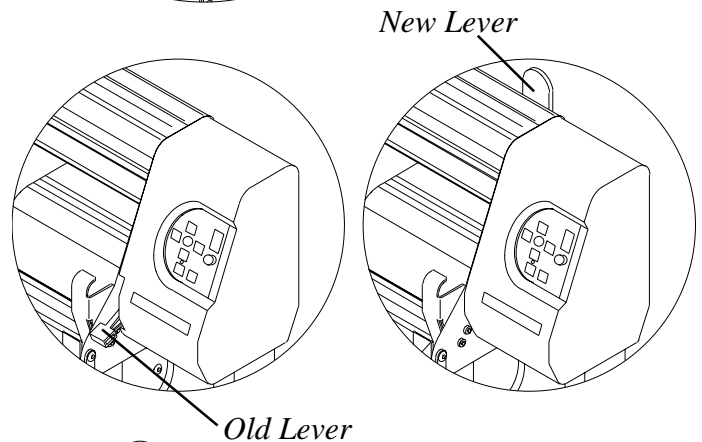

- **Carriage Jaw and Sensor** - The 600A/28A carriage is smaller and lighter than on the 600/28 plotter. It features a more convenient jaw and may have a compact sensor package*.

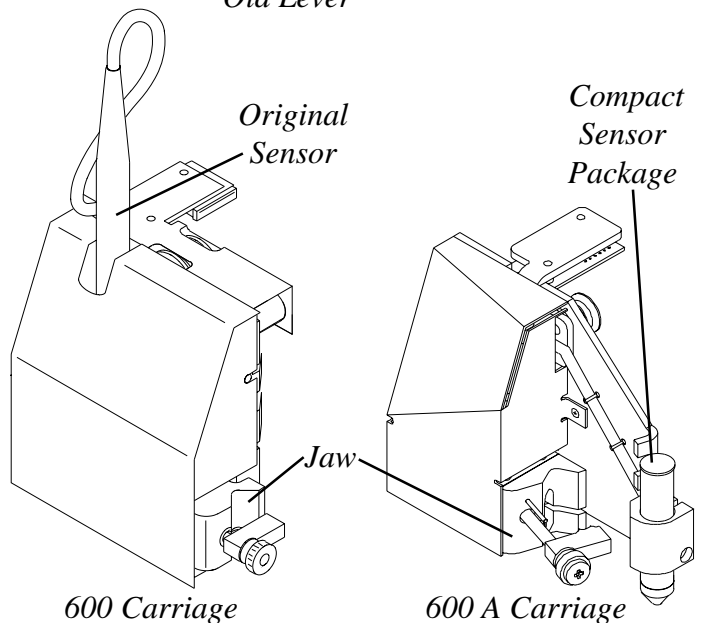

* Sensor included on the 600A model only.